

ITEM NUMBER	MATERIAL	COLOR
43680-2003	UL94V-0 NYLON	BLACK
43680-1003	UL94V-2 NYLON	NATURAL (TRANSLUCENT)

- NOTES:**
1. MATERIAL: SEE CHART.
  2. FINISH: NONE.
  3. PRODUCT SPECIFICATION: PSX-44441-9999.
  4. PACKAGING: PK-43680-001.
  5. THIS CONNECTOR HOUSING FOR USE WITH 43178-\*\*\*\* TERMINALS.
  6. THIS CONNECTOR HOUSING WILL MATE TO 43335-\*\*\*3, 43179-\*\*\*3 AND 44441-\*\*\*3 HOUSINGS.
  7. PARTS CONFORM TO CLASS B REQUIREMENTS OF COSMETIC SPEC PS-45499-002.

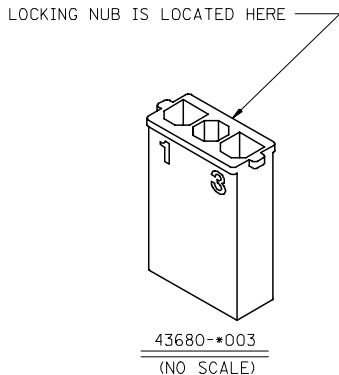

ADD NOTES 2 & 7 EC NO: UCP2008-0911 DRAWN/PRD/DR 2007/11/15 CHKD:LSH/MT 2007/11/16 APPR:FSM/TH 2007/11/16 REV:	QUALITY SYMBOLS	GENERAL TOLERANCES (UNLESS SPECIFIED)	DIMENSION STYLE	SCALE	DESIGN UNITS	THIRD ANGLE PROJECTION																
	$\nabla=0$ $\nabla=0$	<table border="1"> <thead> <tr> <th></th> <th>mm</th> <th>INCH</th> </tr> </thead> <tbody> <tr> <td>4 PLACES</td> <td>± .010</td> <td>± .0004</td> </tr> <tr> <td>3 PLACES</td> <td>± .014</td> <td>± .0005</td> </tr> <tr> <td>2 PLACES</td> <td>± .025</td> <td>± .0010</td> </tr> <tr> <td>1 PLACE</td> <td>± 0.35</td> <td>± .0138</td> </tr> </tbody> </table>		mm	INCH	4 PLACES	± .010	± .0004	3 PLACES	± .014	± .0005	2 PLACES	± .025	± .0010	1 PLACE	± 0.35	± .0138	IN/MM	4:1	INCH		
		mm	INCH																			
	4 PLACES	± .010	± .0004																			
3 PLACES	± .014	± .0005																				
2 PLACES	± .025	± .0010																				
1 PLACE	± 0.35	± .0138																				
DESCRIPTION	<table border="1"> <thead> <tr> <th>DRAWN BY</th> <th>DATE</th> <th>TITLE</th> </tr> </thead> <tbody> <tr> <td>CM</td> <td>03/22/96</td> <td>3-CIR. PLUG HOUSING</td> </tr> <tr> <th>CHECKED BY</th> <th>DATE</th> <th></th> </tr> <tr> <td>KBP</td> <td>03/22/96</td> <td>.125(3.18)X.020(0.51)</td> </tr> <tr> <th>APPROVED BY</th> <th>DATE</th> <th></th> </tr> <tr> <td>RAS</td> <td>03/22/96</td> <td>SABRE - TPA</td> </tr> </tbody> </table>	DRAWN BY	DATE	TITLE	CM	03/22/96	3-CIR. PLUG HOUSING	CHECKED BY	DATE		KBP	03/22/96	.125(3.18)X.020(0.51)	APPROVED BY	DATE		RAS	03/22/96	SABRE - TPA	MATERIAL NO.	DOCUMENT NO.	SHEET NO.
DRAWN BY	DATE	TITLE																				
CM	03/22/96	3-CIR. PLUG HOUSING																				
CHECKED BY	DATE																					
KBP	03/22/96	.125(3.18)X.020(0.51)																				
APPROVED BY	DATE																					
RAS	03/22/96	SABRE - TPA																				
	DRAFT WHERE APPLICABLE MUST REMAIN WITHIN DIMENSIONS	SEE CHART	SD-43680-*003	1 OF 1																		