

ASSEMBLY NUMBER	PT-SE NUMBER	DIMENSIONS														
		C ±.000 -.020	D ±.000 -.020	G ±.025 -.020	H DIA MAX	K ±.025 -.010	L MAX	M ±.010 -.000	N DIA ±.001 -.005	R (TP)	S ±.016	T DIA ±.005	Z ±.055	Z ₁ ±.055	KK DIA ±.011 -.000	SS DIA ±.000 -.016
71-331206-	02SE-6-	NOT AVAILABLE														
71-331208-	-8-	.332	.025	.743	.297	.493	1.328	.431	.473	.594	.812	.120	.509	.448	.438	.563
71-331210-	-10-				.421		1.266		.590	.719	.938				.562	.680
71-331212-	-12-				.546				.750	.812	1.031				.688	.859
71-331214-	-14-				.663				.875	.906	1.125				.812	.984
71-331216-	-16-				.788				1.000	.969	1.219				.938	1.108
71-331218-	-18-				.879				1.125	1.062	1.312				1.062	1.233
71-331220-	-20-	.394	.087	.994	1.014	.650	1.328	.556	1.250	1.156	1.438		.414	.353	1.188	1.358
71-331222-	-22-			.994	1.135	.650		.556	1.375	1.250	1.562		.414	.353	1.312	1.483
71-331224-	-24-			1.058	1.259	.683		.589	1.500	1.375	1.688	.147	.381	.320	1.438	1.612
71-331225/50		NOT AVAILABLE														

REL NO. 36502-358		REVISIONS			COMM REC
CHG NO.	SYM	DESCRIPTION	DATE	APPROVAL	
		FOR CHANGES 1 THRU A5, SEE RECORD DRAWING			
59847	B	(MFG) ADDED NOTE 15	8-9-78 L. HALL	<i>[Signature]</i>	

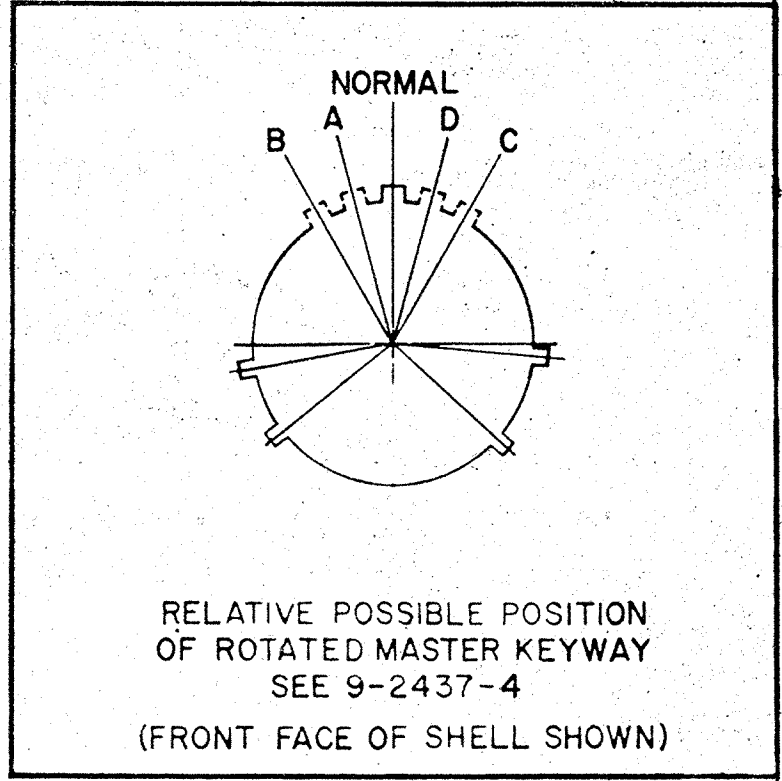
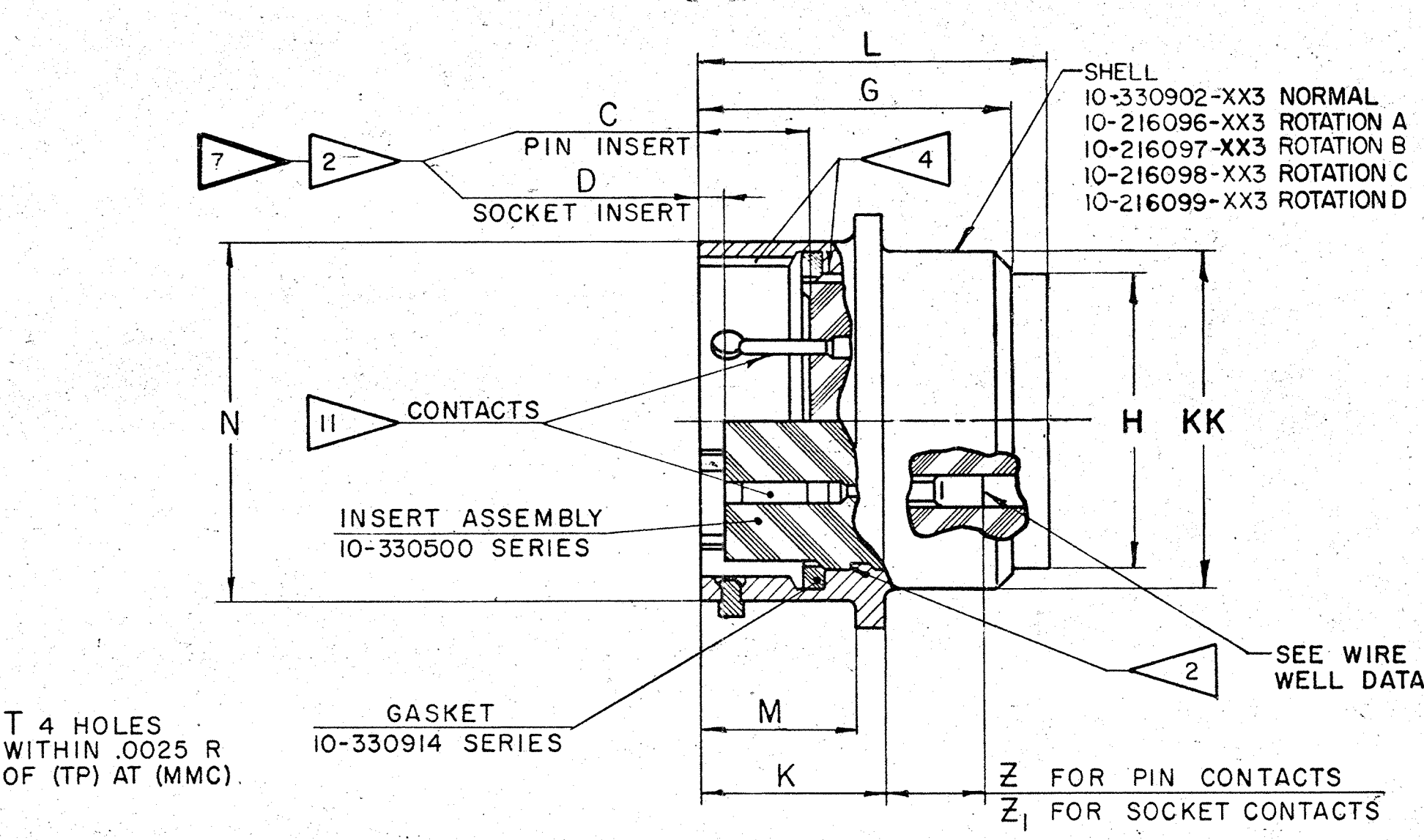
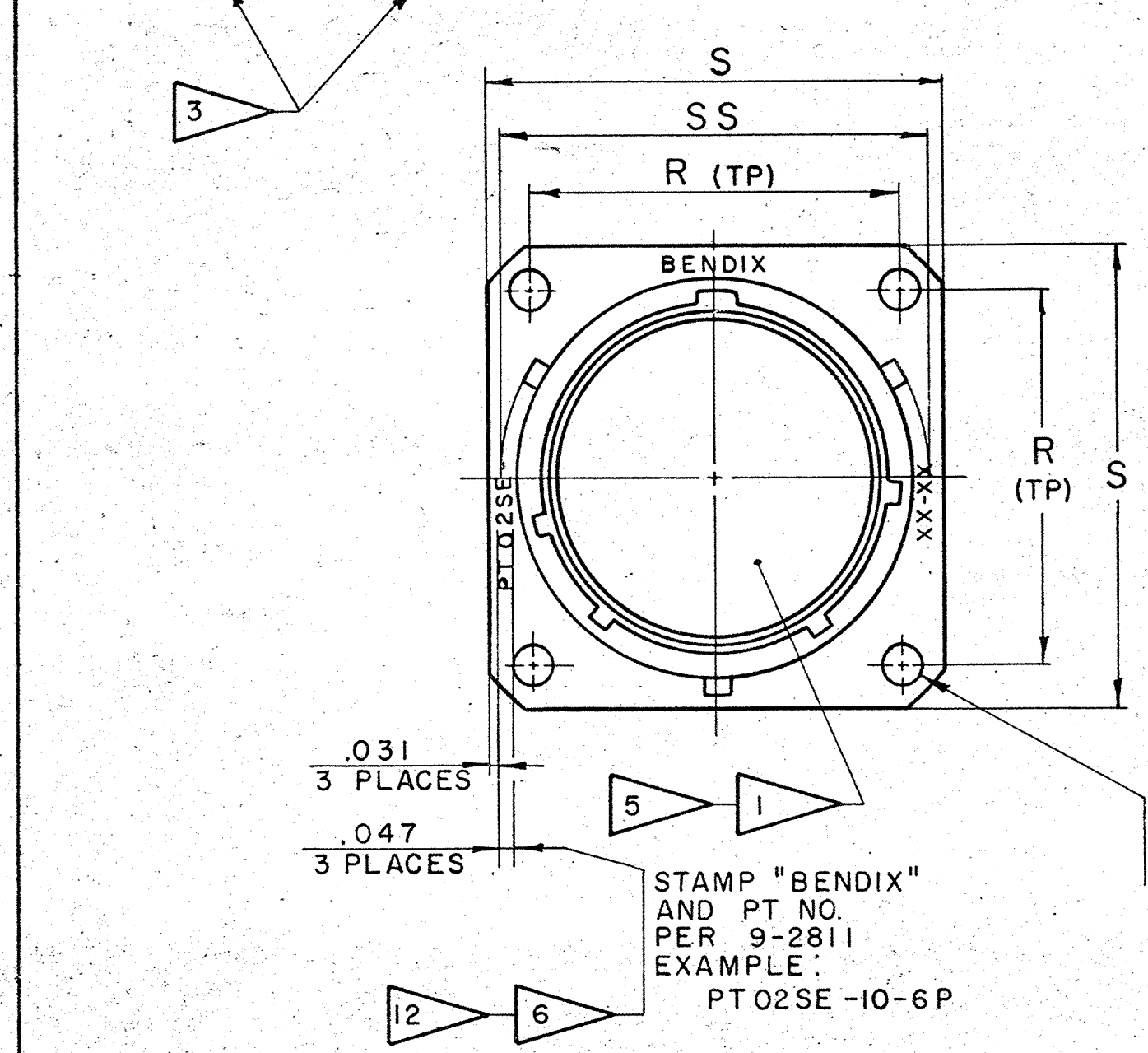

- NOTES:
- FOR CONTACT ARRANGEMENTS & COAXIAL CONTACT DATA, SEE DRAWINGS L-15206-() THRU L-15250-().
 - DIMENSIONS MUST BE MAINTAINED WHEN INSERTS ARE PRESSED FIRMLY AGAINST INDICATED SHOULDER.
 - TO COMPLETE ASSEMBLY NO. & PT-SE NO., ADD APPLICABLE INSERT ARRANGEMENT SUFFIX TO BASE NUMBERS LISTED ABOVE PER 9-2437-1 OR 9-2437-4.
 - VERTICAL CENTERLINES OF INSERT ARRANGEMENT & THE MAIN SHELL POLARIZING KEYWAY TO BE WITHIN .005 OF INDICATED ROTATION PER 9-2437-1.
 - INSERT ASSEMBLIES ARE NOT REMOVABLE.
 - SEE WORK ORDER FOR PERMISSIBLE ADDITIONAL OR ALTERNATE STAMPING.
 - INSERT LOCATING DIMENSIONS APPLY BEFORE ASSEMBLY OF CONTACTS.
 - FOR COMPONENT PART NUMBERS OF DESIRED ARRANGEMENT, SEE APPLICABLE PARTS LIST (PL).
 - SEE DRAWING 71-331606/50 & OTHERS FOR REQUIRED MATING PLUG ASSEMBLY.
 - STAMPING MAY BE ON EITHER SIDE OF FLANGE (ONE SIDE ONLY).
 - PLACE CONTACTS IN AN APPLICABLE POLYETHYLENE BAG 10-215999 SERIES (SEE PARTS LIST) & INCLUDE IN A POLYETHYLENE BAG CONTAINING CONNECTOR.
 - UNITS ILLUSTRATED MEET THE MATERIAL & FINISH REQUIREMENTS OF MIL-C-26482.
 - FOR FINAL INSTALLATION, CONTACTS MUST BE ASSEMBLED INTO ALL INSERT HOLES.
 - SEE INDIVIDUAL DRAWINGS FOR 71-331214-22, 71-331214-91, 71-331218-91 & 71-331222-96.

WIRE WELL DATA			
CONTACT SIZE	20	16	
CONDUCTOR WELL DIA	.048 +.002 -.000	.066 +.002 -.000	
CONDUCTOR WELL DEPTH	.184 +.037 -.000	.234 +.031 -.000	
INSULATION WELL DIA	.091 +.002 -.000	NOT AVAILABLE	COAXIAL DATA
INSULATION WELL DEPTH	.077 +.006 -.000	NOT AVAILABLE	SEE NOTE 1

ACCESSORIES				
(NOT PART OF STANDARD ASSEMBLY)				
SEE DRAWING			10-150000	

TEST 9-4039-1
ASSY 9-3836, 9-2437-19-2437-4
9-2811

UNLESS OTHERWISE SPECIFIED:

1. TOLERANCES UNLESS OTHERWISE SPECIFIED:
ANGULAR .015
2. ALL LOCATIONS TOLERANCES APPLY AT MAXIMUM MATERIAL CONDITION (MMC).
3. RADIUS FILLETS & BREAK EDGES .005-.010
4. DIMENSIONS TO CENTER UNLESS OTHERWISE SPECIFIED.
FOR DIMENSIONS INTERPRETATION SEE SPEC 9-2811.

ABBREVIATIONS & SYMBOLS
MAY BE FOUND IN THE DRAWING
ORIG ENG JOB NO 996

DRAWN E. FLEMING DATE 12-19-60
CHECKED Mero DATE 12-19-60
MATERIAL

FINISH SPEC
HEAT TREAT SPEC

SCALE NONE WT CALC (SEE ACT. PL) LBS 71-196-05/50

LIST OF MATERIAL

ITEM	REQD	PART NO	DESCRIPTION	UNIT WT	NEXT ASSY	USED ON
CONNECTOR, ELECTRICAL RECEPTACLE, TYPE PT-SE()FB, OLIVE DRAB						

APPLICATION

SCINTILLA DIVISION
BENDIX AVIATION CORPORATION
SIDNEY, N. Y., U.S.A.

71-331206 THRU 71-331250

DRAWING C TAB

CODE 77820

71-331206 THRU 71-331250