

NOTES:

1. MATERIALS AND FINISHES:
 BODY - PHOSPHOR BRONZE, NICKEL PLATING (.0001" THICK)
 CONTACT - BRASS, GOLD PLATING (.00003" THICK)
 FERRULE - BRASS, NICKEL PLATING (.0001" THICK)
 INSULATOR - PTFE

2. ELECTRICAL:
 A. IMPEDANCE: 75 OHM
 B. FREQUENCY RANGE: DC - 4 GHz
 C. VSWR(RETURN LOSS): 1.3 MAX.
 D. DIELECTRIC WITHSTANDING VOLTAGE: 1500 VRMS, MIN.

3. MECHANICAL:
 A. DURABILITY: 500 CYCLES MIN.
 B. TEMPERATURE RANGE: -65° C TO +165° C

4. FERRULE TO BE CRIMPED WITH A .324 HEX DIE.
 CONTACT TO BE CRIMPED WITH A .042 SQUARE DIE
 OR A 8 PT CRIMPER AMPHENOL NUMBER 227-T1200

5. SHOWS CABLE ENTRY DIMENSIONS.

THIRD ANGLE PROJ.

REVISIONS

REV	DESCRIPTION	DATE	ECO	APPR
A	RELEASE TO MFG	4/10/06	45950	MY
B	NOTE 4 SHT 2 'OR A 12 POINT... INDENTOR TOOL'; .255 WAS .178	5/11/06	46083	CPM
C	SEE SHEET 1	8/10/06	46212	GSA
D	NOTE 4 '8 PT CRIMPER AMPHENOL NUMBER CTL-T1200'	8/6/07	46681	TC
E	227-T1200 WAS CTL-T1200\RD-DM110704011 INSIDE SPRING WAS CHANGED\RD-DM09080201K	15-Jul-11	48649	DH
F	STAMP WAS CHANGED\RD-DM110825011	05-Sep-11	48757	SCOTT

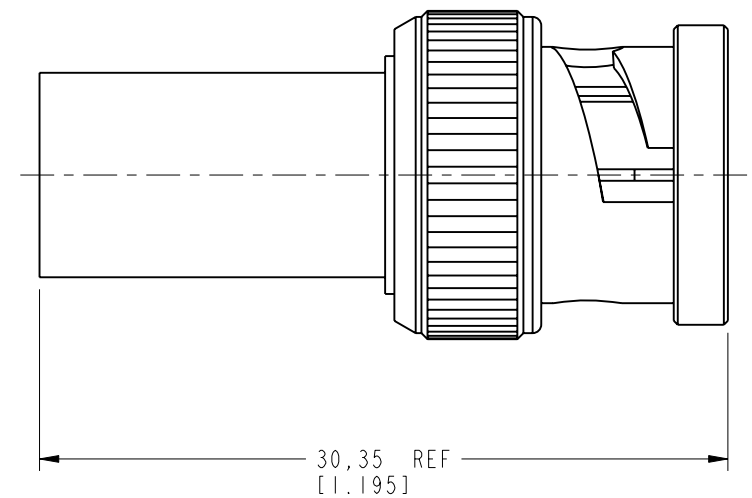

AFTER ASSEMBLY DIMENSIONS

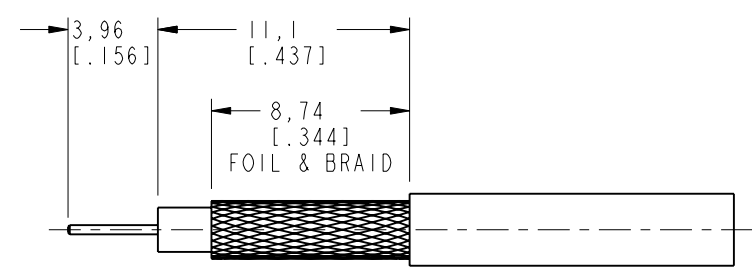

RECOMMENDED
CABLE STRIPPING DIMENSIONS

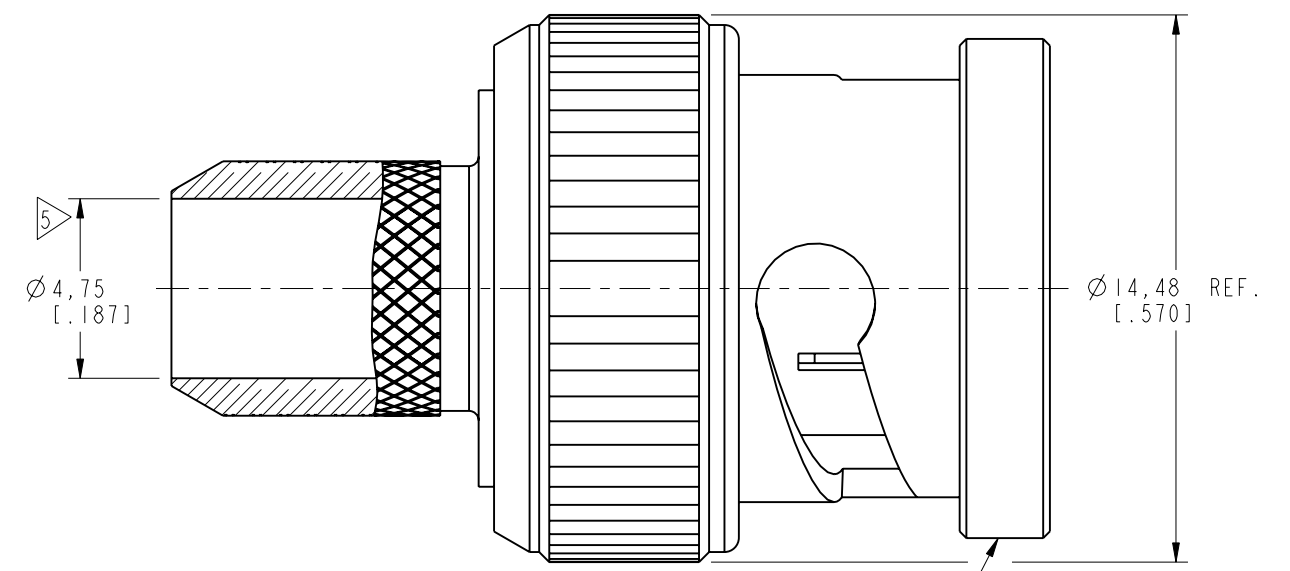
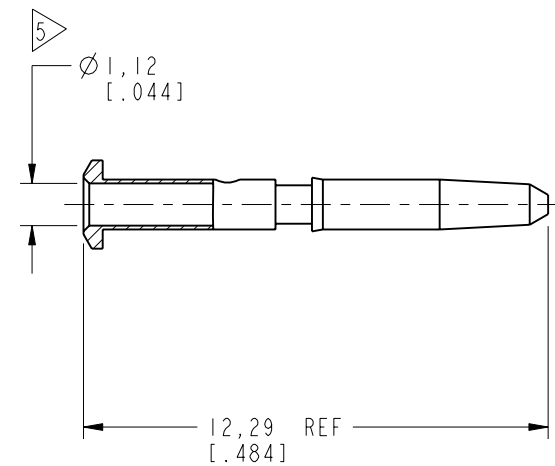
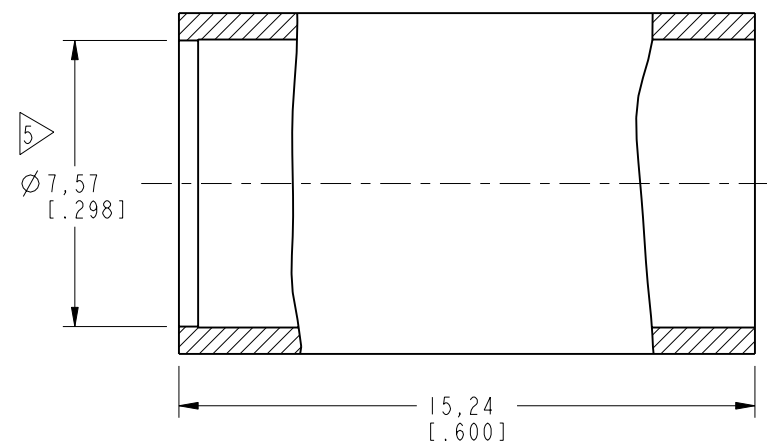
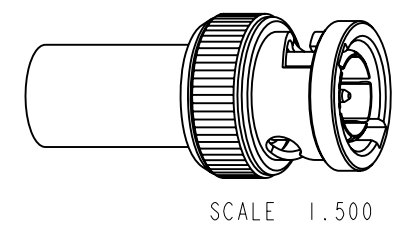

CUSTOMER OUTLINE DRAWING
 ALL OTHER SHEETS ARE FOR INTERNAL USE ONLY

UNLESS OTHERWISE SPECIFIED, DIMENSIONS ARE IN METRIC AND TOLERANCES ARE: <0.5mm ±0.05mm 0.5 - 6mm ±0.1mm 6 - 30mm ±0.2mm 30 - 120mm ±0.3mm ANGLES ±1°	MATERIAL	DRAWN	DATE	TITLE	Amphenol RF Danbury CT USA, Tainan, Taiwan, Shenzhen, China www.amphenolrf.com
	SEE NOTE	I. XU	25-Aug-11		
	REFERENCE	ENGINEER	DATE	SCALE: 5.0:1.0 SHEET 2 OF 2	
	EAR # 1674 AND 611x-3996	G. ANTONINI	03-Mar-05	DWG SIZE B REV F	
NOTICE - These drawings, specifications, or other data (1) are, and remain the property of Amphenol corp. (2) must be returned upon request; and (3) are confidential and not to be disclosed to any person other than those to whom they are given by Amphenol Corp. the finishing of these drawings, specifications, or other data by Amphenol Corp., or to any other person to anyone for any purpose is not to be regarded by implication or otherwise in any manner licensing, granting rights to permitting such holder or any other person to manufacture, use or sell any product, process or design, patented or otherwise, that may in any way be related to or disclosed by said drawings, specifications, or other data.	CONFIGURATION LEVEL: <input type="checkbox"/> <input type="checkbox"/> <input type="checkbox"/> <input type="checkbox"/>	APPROVED S. HSIEH	DATE 05-Sep-11	DRAWING NO. 31-80109 ITEM NO. 31-80109 PART NO. 31-80109	