

Part Number & Date Code Printing
 PC card drilling dimensions(after plating)
 (thickness 1.60±0.20mm)

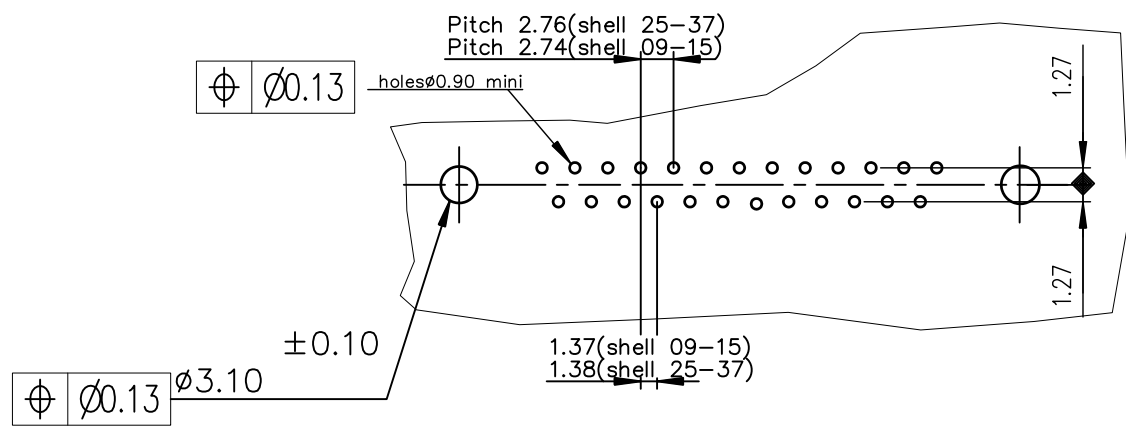

Pull Parts							
SHELL	A±0.38	B±0.12	C±0.10	D±0.25	PART NUMBER	LEAD FREE P/N	
09	30.81	24.99	16.96	16.21	D09S13A*GX00	D09S13A*GX00LF	
15	39.14	33.32	25.18	24.54	D15S13A*GX00	D15S13A*GX00LF	
25	53.03	47.04	39.12	38.25	D25S13A*GX00	D25S13A*GX00LF	
37	69.32	63.50	55.68	54.71	D37S13A*GX00	D37S13A*GX00LF	

4-200 MATING CYCLES
 6-500 MATING CYCLES

GENERAL CHARACTERISTICS : SEE DRAWING C01-8646-0000

mat'l. code SEE.NOTES				surface ISO 1302 ✓		tolerance ISO 406 ISO 1101		projection MM		product family D-SUB	
ltr	ecn no	dr	date	tolerances unless otherwise specified							
K	ELX-I-18948	AB	2014/09/29	angles		linear		O.X ±0.1 O.XX ±0.1 O.XXX±0.1		title SOCKET CONNECT.DELTA D RIGHT ANGLE WITH NUT,HARPON and metal plate.	
				0.XX±2°				scale 1:1		dwg no C01-8646-0294	
				dr		engr		chr		sheet 1 of 1 size 5	
				JOHN.SLEEBA		ALIAS.BABU		MITHUN.PAUL		A3	
				2014/10/14		2014/09/29		2014/09/29		type CUSTOMER Drawing	
				appd		BIJU.K.PAUL		2014/09/29			
sheet index		revision sheet		K 1							