

DESCRIPTION: MALE - DIP SOLDER - MACHINED - ECONOMY

No. OF PINS	DIMENSIONS							
	A	B	C	D	E	F	G	H
9	1.213	0.984	0.666	0.329	0.236	0.756	0.496	0.427
	30.80	24.99	16.92	8.36	5.99	19.20	12.60	10.85
15	1.541	1.312	0.994	0.329	0.236	1.091	0.496	0.427
	39.15	33.32	25.25	8.36	5.99	27.70	12.60	10.85
25	2.087	1.852	1.534	0.329	0.236	1.618	0.496	0.427
	53.00	47.04	38.96	8.36	5.99	41.10	12.60	10.85

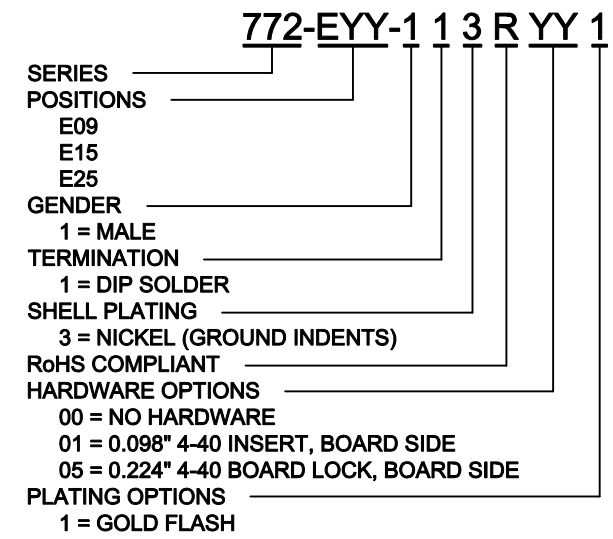
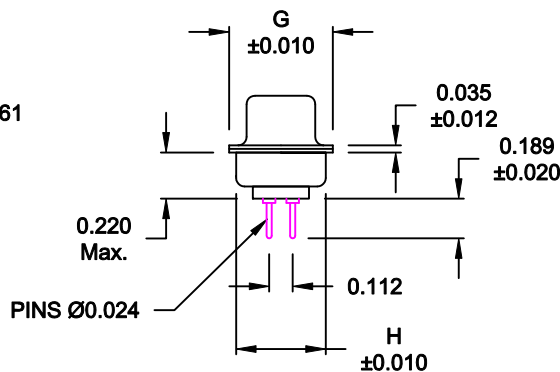
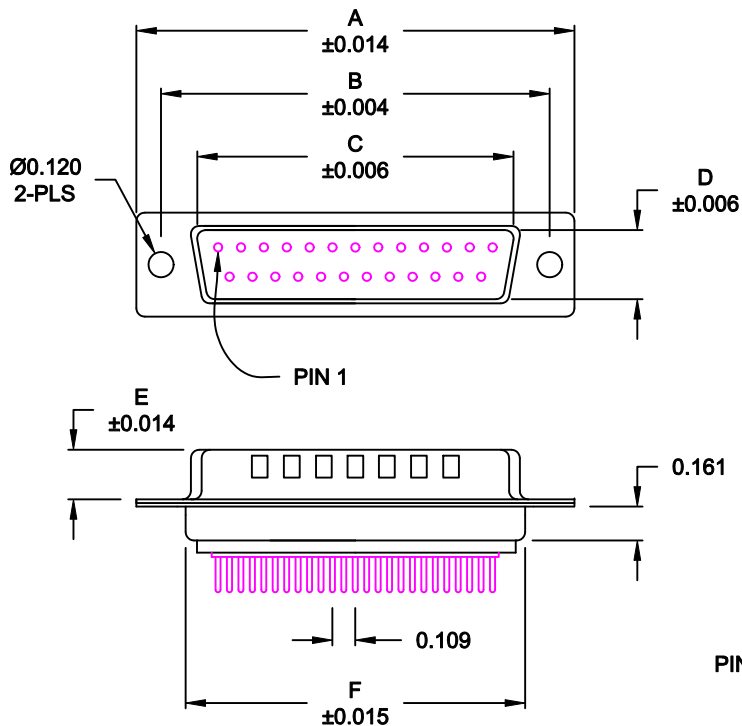

**MATERIAL:**

SHELL: STEEL, NICKEL PLATED  
 INSULATOR: UL 94V-O RATED, WHITE PA6T  
 PROCESS TEMP.: 260° C  
 CONTACT: BRASS  
 SEALING MATERIAL: F08 FLEXIBLE ADHESIVE

**ELECTRICAL:**

CURRENT RATING: 5 AMPS  
 CONTACT RESISTANCE: 15 mOhms Max.  
 INSULATION RESISTANCE: 1,000 MOhms min.  
 VOLTAGE: 500VAC FOR 1 MINUTE  
 TEMPERATURE: -50° C TO 100° C

**MEETS IP67 STANDARDS**  
 (SEE PAGE 3 FOR SEALING DETAILS)

DO NOT SCALE FROM DRAWING

	THESE DRAWINGS AND SPECIFICATIONS ARE THE PROPERTY OF NorComp AND SHALL NOT BE REPRODUCED, COPIED OR USED AS THE BASIS FOR THE MANUFACTURE OF SALE OF APPARATUS WITHOUT WRITTEN PERMISSION.		DRAWN: PAM JENKINS	DATE: 9-18-08
			CHECKED:	DATE:
<h1>NorComp</h1>		SCALE: 1:1	SHEET 1 OF 3	REV 3
		DWG NO. 772-EYY-113RYY1		

RoHS COMPLIANT

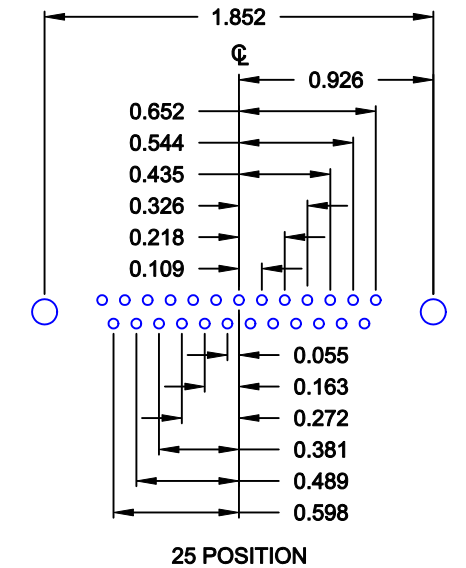
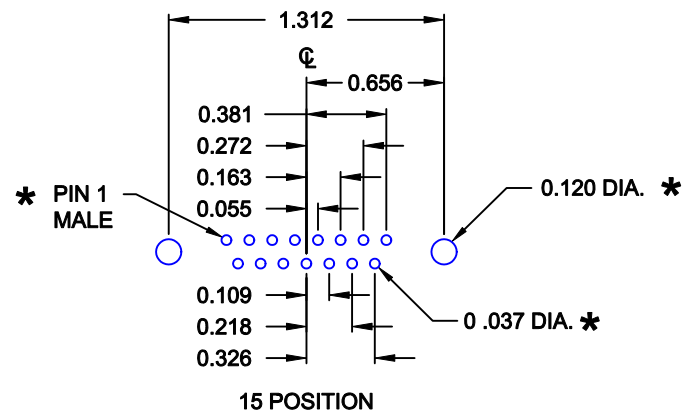
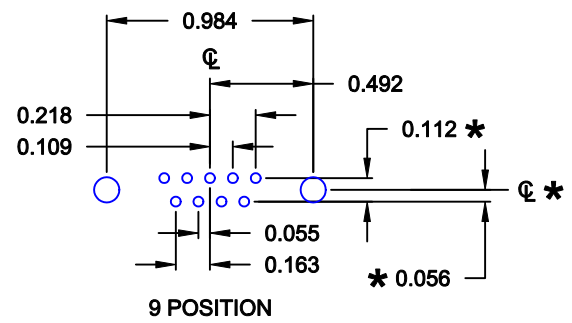

\* TYP. ON ALL SIZES

DO NOT SCALE FROM DRAWING

	THESE DRAWINGS AND SPECIFICATIONS ARE THE PROPERTY OF NorComp AND SHALL NOT BE REPRODUCED, COPIED OR USED AS THE BASIS FOR THE MANUFACTURE OF SALE OF APPARATUS WITHOUT WRITTEN PERMISSION.		DRAWN: <b>PAM JENKINS</b>	DATE: <b>9-18-08</b>
			CHECKED:	DATE:
<h1>NorComp</h1>		SCALE: <b>FULL</b>	SHEET <b>2</b> OF <b>3</b>	REV <b>3</b>
		DWG NO. <b>772-EYY-113RYY1</b>		

### HARDWARE OPTIONS

ALL CLINCH-NUTS ARE 4-40 INTERNAL THREADS

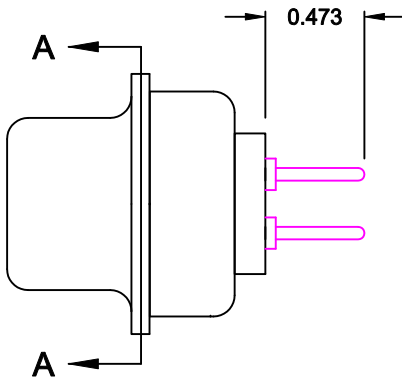

FRONT SEAL APPLIED OVER INSULATOR AND BETWEEN FRONT & REAR SHELLS

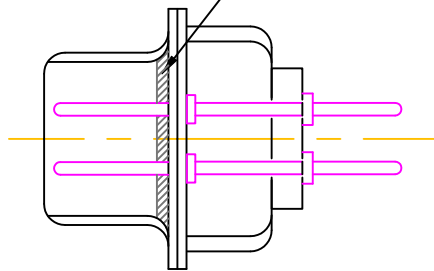

DETAIL A-A

01X ..... 0.098" (BOARD SIDE) - CN1

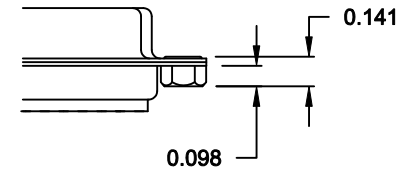

05X ..... 0.224" BOARD SIDE - CN10

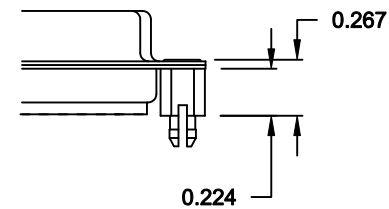

DO NOT SCALE FROM DRAWING



THESE DRAWINGS AND SPECIFICATIONS ARE THE PROPERTY OF NorComp AND SHALL NOT BE REPRODUCED, COPIED OR USED AS THE BASIS FOR THE MANUFACTURE OF SALE OF APPARATUS WITHOUT WRITTEN PERMISSION.

DRAWN:  
**C. SMITH**

DATE:  
**06-10-09**

CHECKED:

DATE:

# NorComp

SCALE: **2.5 : 1** SHEET **3** OF **3** REV **3**

DWG NO. **772-EYY-113RYY1**