

LOC	DIST	REVISIONS			
DF	AO	REV	DATE	BY	APPV
		B	05FEB2013	MGM	CT

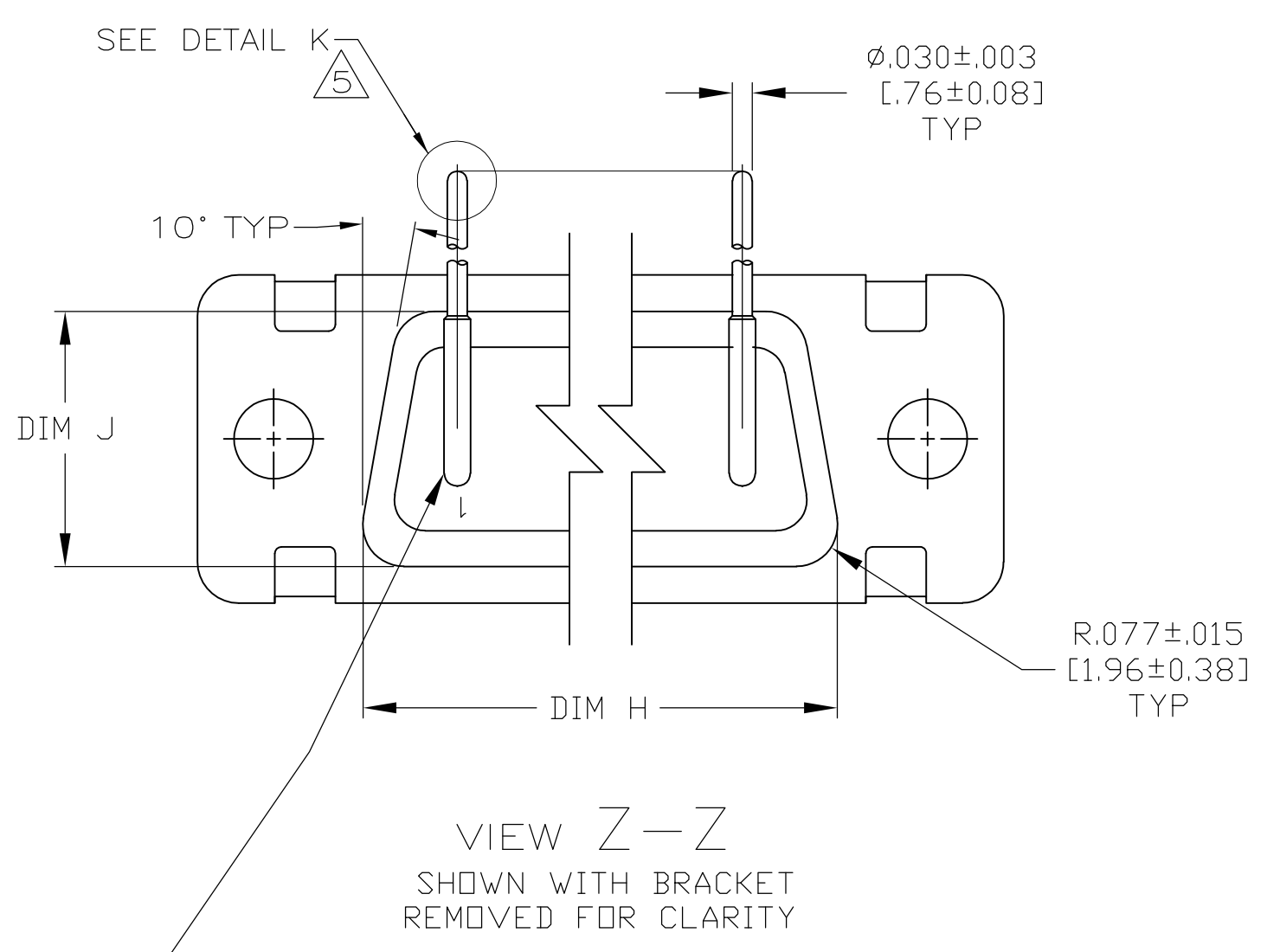
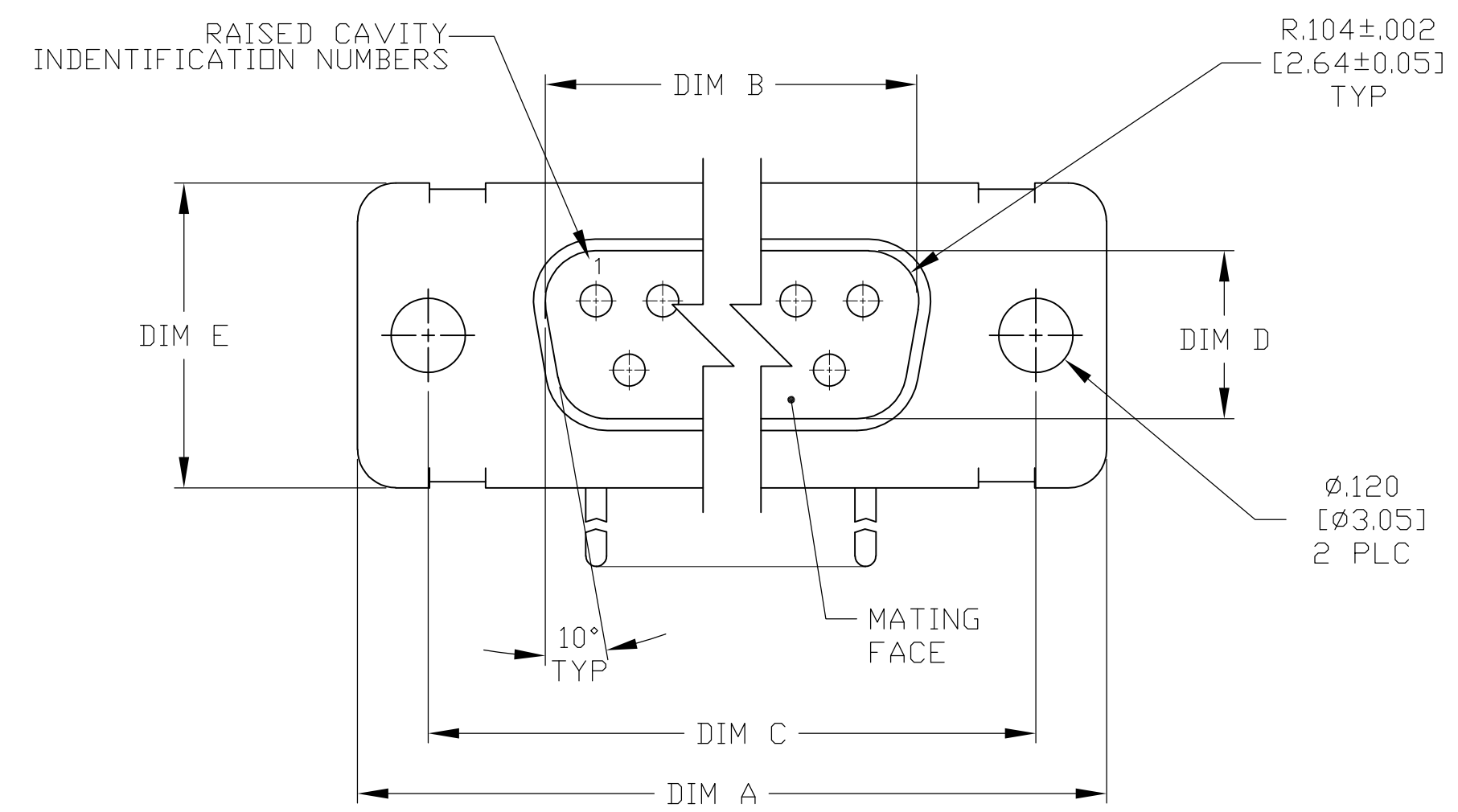

VIEW Z-Z
SHOWN WITH BRACKET REMOVED FOR CLARITY

CONTACT (QTY = NO. OF POSN)
MATL: BRASS PER ASTM-B-16, OR BERYLLIUM COPPER PER ASTM-B-194
FINISH: GOLD PER ASTM-B-488, TYPE II, GRADE C, CLASS 1.27 IN CONTACT MATING AREA, .000010 [0.0003] MIN THK GOLD PER ASTM-B-488 OVER .000050 [0.0013] MIN THK NICKEL PER SAE-AMS-QQ-N-290 ON CONTACT BODY

- SEE SHEET 2 FOR RECOMMENDED P.C. BOARD LAYOUT. TRUE POSITION TOLERANCE FOR P.C. BOARD LAYOUT IS .010 [0.25] AT MAX MATERIAL CONDITION. SUGGESTED BOARD THICKNESS IS .062 [1.57]
- THE CONNECTORS DESCRIBED IN THIS DOCUMENT MEET THE REQUIREMENTS OF MIL-C-24308 AND MATE WITH ANY RECEPTACLE CONNECTOR WITH SAME INSERT ARRANGEMENT.
- MARKED WITH .047 [1.19]-.062 [1.57] HIGH CHARACTERS. FAR SIDE REFERS TO THE WIDE SIDE OF THE KEYSTONE. NEAR SIDE REFERS TO THE NARROW SIDE OF THE KEYSTONE. IF THE SHELL IS TOO SMALL FOR THE ENTIRE MARKING MARKING SHALL BE SPLIT AS FOLLOWS:
A. "M24308" ON FRONT SHELL, FAR SIDE.
B. SLASH SHEET AND DASH NUMBER ON REAR SHELL, FAR SIDE.
C. "MFG'S" (NAME, BRAND OR LOGO) AND DATE CODE ON FRONT SHELL, NEAR SIDE.
D. MFG'S PART NUMBER ON REAR SHELL, NEAR SIDE.
- REQUIREMENT FOR FULL PIN DIAMETER EXTENSION:
.159 [4.04] MIN, SHELL SIZES 1 AND 2.
.150 [3.81] MIN, SHELL SIZES 3 AND 4.
- SOLDER DIPPED PER J-STD-001 WITH Sn63 SOLDER PER J-STD-006 IN THE ENTIRE AREA OF DIMENSION SHOWN. (1757839-6 THRU -10 ONLY.)
- MEETS SOLDERABILITY PER MIL-STD-202 METHOD 208.

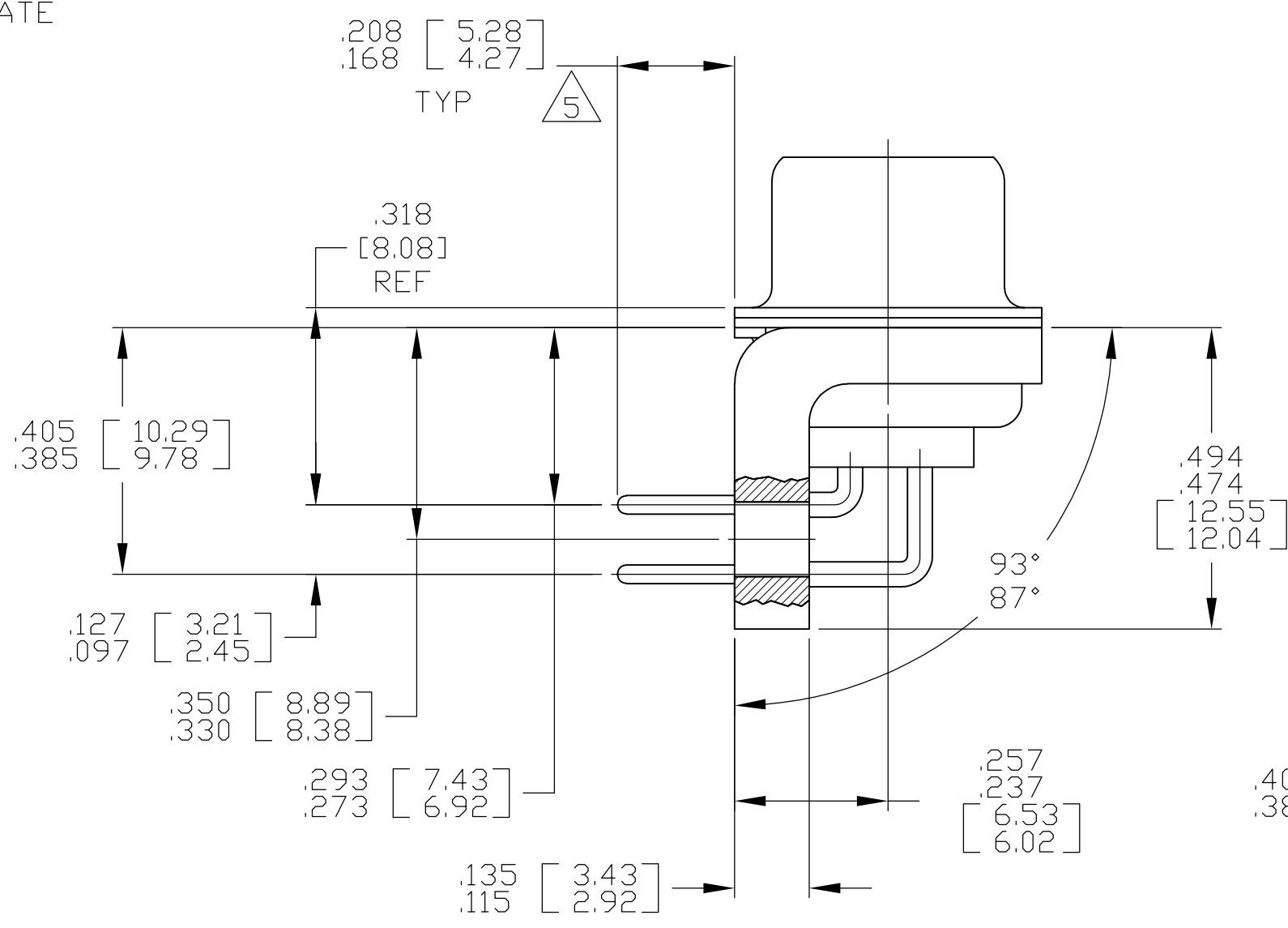
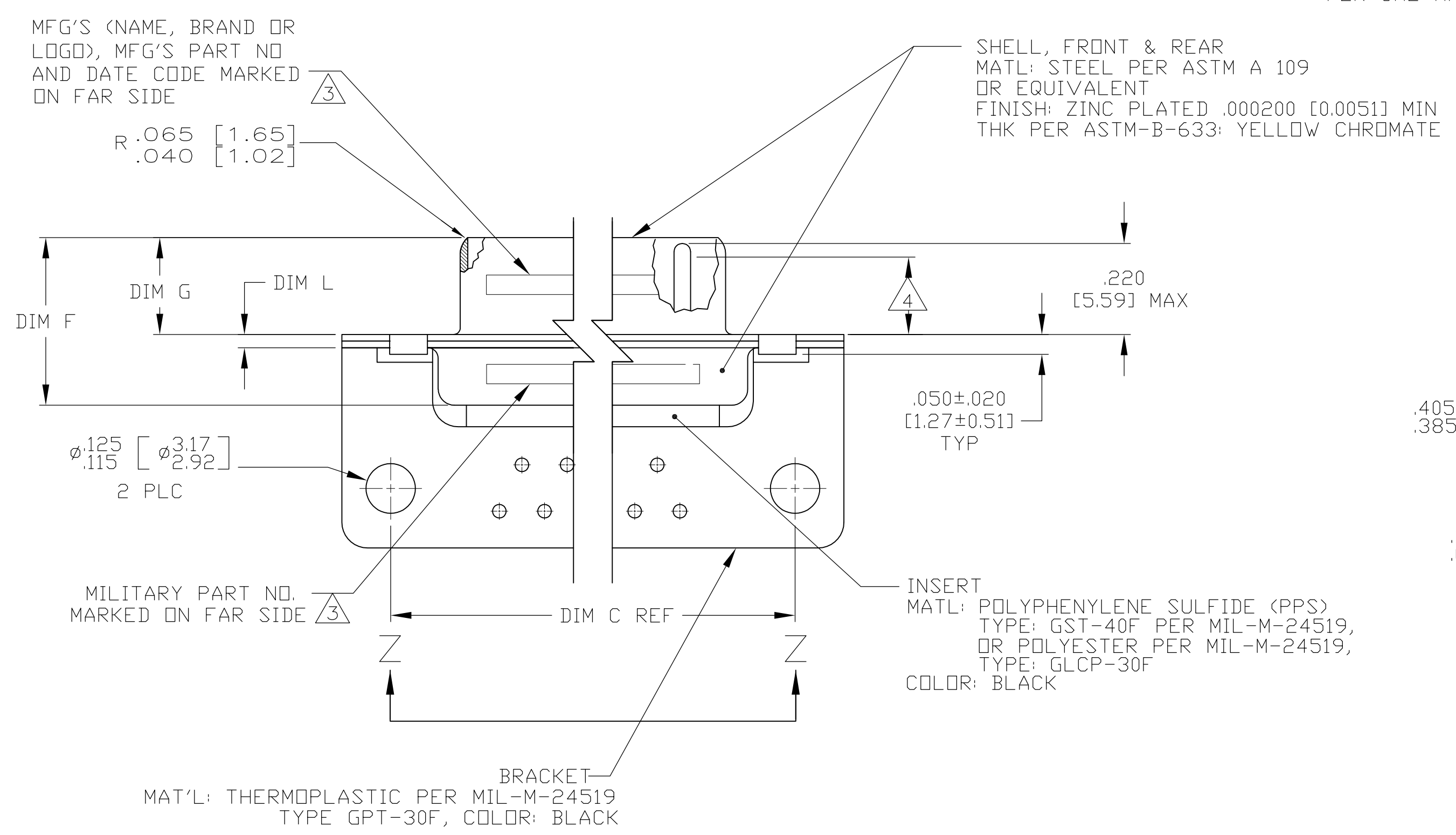

SHELL SIZES 1 THRU 4 CONTACT CONFIGURATION

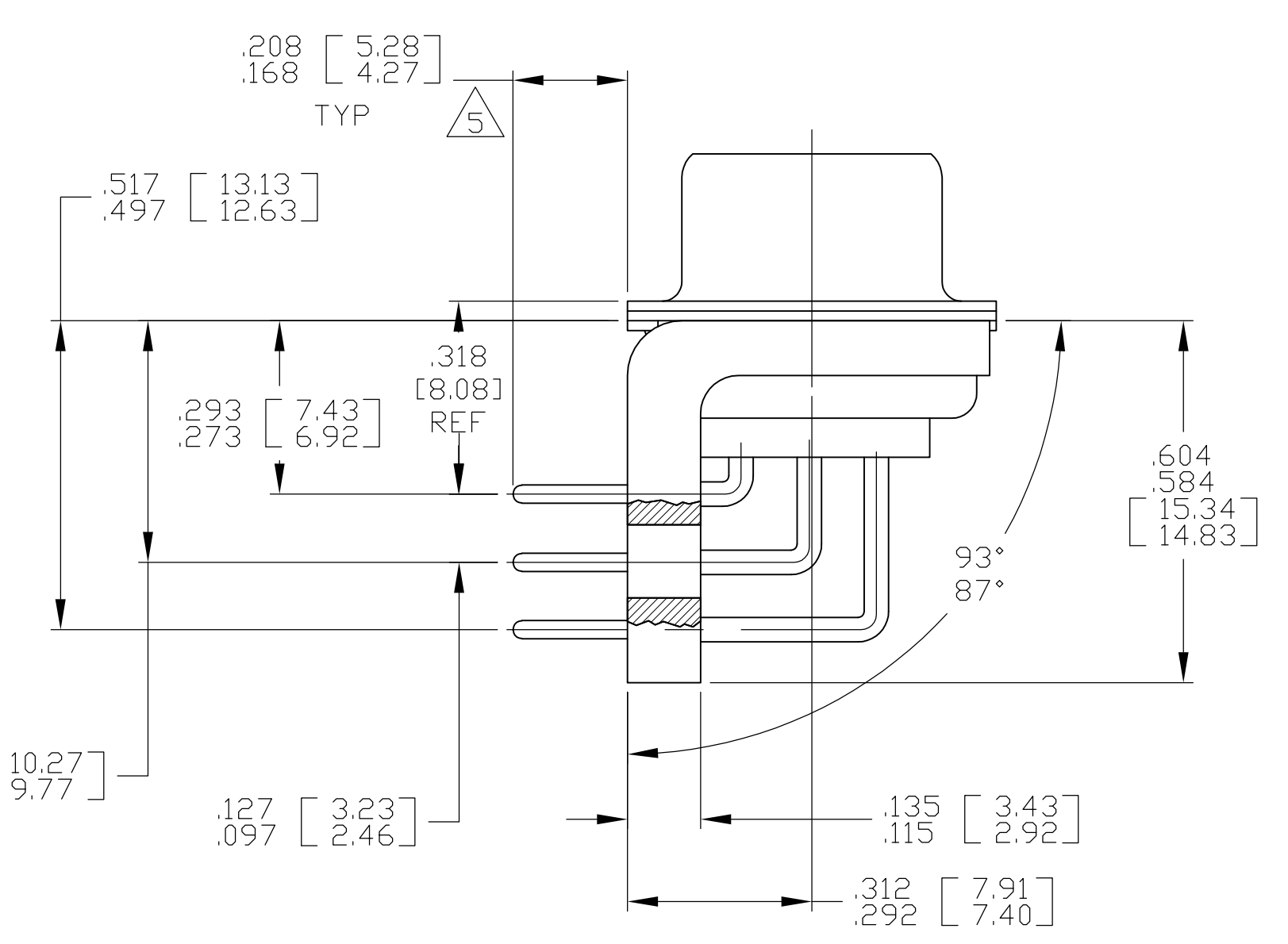

SHELL SIZE 5 CONTACT CONFIGURATION

.030 [0.76] MAX EXTENSION PERMISSIBLE DUE TO SOLDER DIPPING

.049 [1.24] .544 [13.82] 2.188 [55.58] .236 [5.99] .436 [11.07] .620 [15.75] .446 [11.33] 2.411 [61.24] 2.084 [52.55] 2.650 [67.31]	.029 [0.74] .524 [13.31] 2.168 [55.07] .224 [5.69] .416 [10.57] .590 [14.99] .436 [11.07] 2.401 [60.99] 2.074 [52.30] 2.620 [66.55]	.049 [1.24] .432 [10.97] 2.282 [57.96] .236 [5.99] .436 [11.07] .509 [12.93] .334 [8.48] 2.505 [63.63] 2.187 [54.97] 2.744 [69.70]	.029 [0.74] .412 [10.46] 2.262 [57.45] .224 [5.69] .416 [10.57] .479 [12.17] .324 [8.23] 2.495 [63.37] 2.177 [54.71] 2.714 [68.94]	.049 [1.24] .432 [10.97] 1.635 [41.53] .236 [5.99] .436 [11.07] .509 [12.93] .334 [8.48] 1.857 [47.17] 1.539 [38.51] 2.103 [53.42]	.029 [0.74] .412 [10.46] 1.615 [41.02] .224 [5.69] .416 [10.57] .479 [12.17] .324 [8.23] 1.847 [46.91] 1.529 [38.25] 2.073 [52.65]	.040 [1.02] .432 [10.97] 1.093 [27.76] .238 [6.05] .432 [10.97] .509 [12.93] .334 [8.48] 1.317 [33.45] .999 [24.79] 1.556 [39.52]	.020 [0.51] .412 [10.46] 1.073 [27.25] .229 [5.82] .412 [10.46] .479 [12.17] .324 [8.23] 1.307 [33.20] .989 [24.54] 1.526 [38.76]	.040 [1.02] .432 [10.97] .769 [19.53] .238 [6.05] .432 [10.97] .509 [12.93] .334 [8.48] .989 [25.12] .671 [16.46] 1.228 [31.19]	.020 [0.51] .412 [10.46] .749 [19.02] .229 [5.82] .412 [10.46] .479 [12.17] .324 [8.23] .979 [24.87] .661 [16.21] 1.198 [30.43]	.049 [1.24] .544 [13.82] 2.188 [55.58] .236 [5.99] .436 [11.07] .620 [15.75] .446 [11.33] 2.411 [61.24] 2.084 [52.55] 2.650 [67.31]	.029 [0.74] .524 [13.31] 2.168 [55.07] .224 [5.69] .416 [10.57] .590 [14.99] .436 [11.07] 2.401 [60.99] 2.074 [52.30] 2.620 [66.55]	.049 [1.24] .432 [10.97] 2.282 [57.96] .236 [5.99] .436 [11.07] .509 [12.93] .334 [8.48] 2.505 [63.63] 2.187 [54.97] 2.744 [69.70]	.029 [0.74] .412 [10.46] 2.262 [57.45] .224 [5.69] .416 [10.57] .479 [12.17] .324 [8.23] 2.495 [63.37] 2.177 [54.71] 2.714 [68.94]	.049 [1.24] .432 [10.97] 1.635 [41.53] .236 [5.99] .436 [11.07] .509 [12.93] .334 [8.48] 1.857 [47.17] 1.539 [38.51] 2.103 [53.42]	.029 [0.74] .412 [10.46] 1.615 [41.02] .224 [5.69] .416 [10.57] .479 [12.17] .324 [8.23] 1.847 [46.91] 1.529 [38.25] 2.073 [52.65]	.040 [1.02] .432 [10.97] 1.093 [27.76] .238 [6.05] .432 [10.97] .509 [12.93] .334 [8.48] 1.317 [33.45] .999 [24.79] 1.556 [39.52]	.020 [0.51] .412 [10.46] 1.073 [27.25] .229 [5.82] .412 [10.46] .479 [12.17] .324 [8.23] 1.307 [33.20] .989 [24.54] 1.526 [38.76]	.040 [1.02] .432 [10.97] .769 [19.53] .238 [6.05] .432 [10.97] .509 [12.93] .334 [8.48] .989 [25.12] .671 [16.46] 1.228 [31.19]	.020 [0.51] .412 [10.46] .749 [19.02] .229 [5.82] .412 [10.46] .479 [12.17] .324 [8.23] .979 [24.87] .661 [16.21] 1.198 [30.43]
---	---	--	--	--	--	---	---	---	---	---	---	--	--	--	--	---	---	---	---

DIM L	DIM J	DIM H	DIM G	DIM F	DIM E	DIM D	DIM C	DIM B	DIM A	INSERT ARRANGEMENT	NO OF POS	SHELL SIZE	MILITARY P/N ON CONNECTOR	MFG'S P/N MARKED ON CONNECTOR	MFG'S PART NO.
-------	-------	-------	-------	-------	-------	-------	-------	-------	-------	--------------------	-----------	------------	---------------------------	-------------------------------	----------------

DETAIL K
SCALE 10:1
FOR 1757839-6 THRU -10 ONLY

THIS DRAWING IS A CONTROLLED DOCUMENT.

DTN: C.C. THOMAS 2-23-06
CHK: D. MILLER 2-23-06
APPV: D. MILLER 2-23-06

STE TE Connectivity

PLUG ASSEMBLY, AMPLIMITE, RT ANGLE, SERIES 109, SIZE 1 THRU 5

APPLIC. SPEC: MIL-C-24308

SIZE: A1 CASE CODE: 00779 DRAWING NO: 1757839

CUSTOMER DRAWING SCALE: 4:1 SHEET: 1 OF 2 REV: B

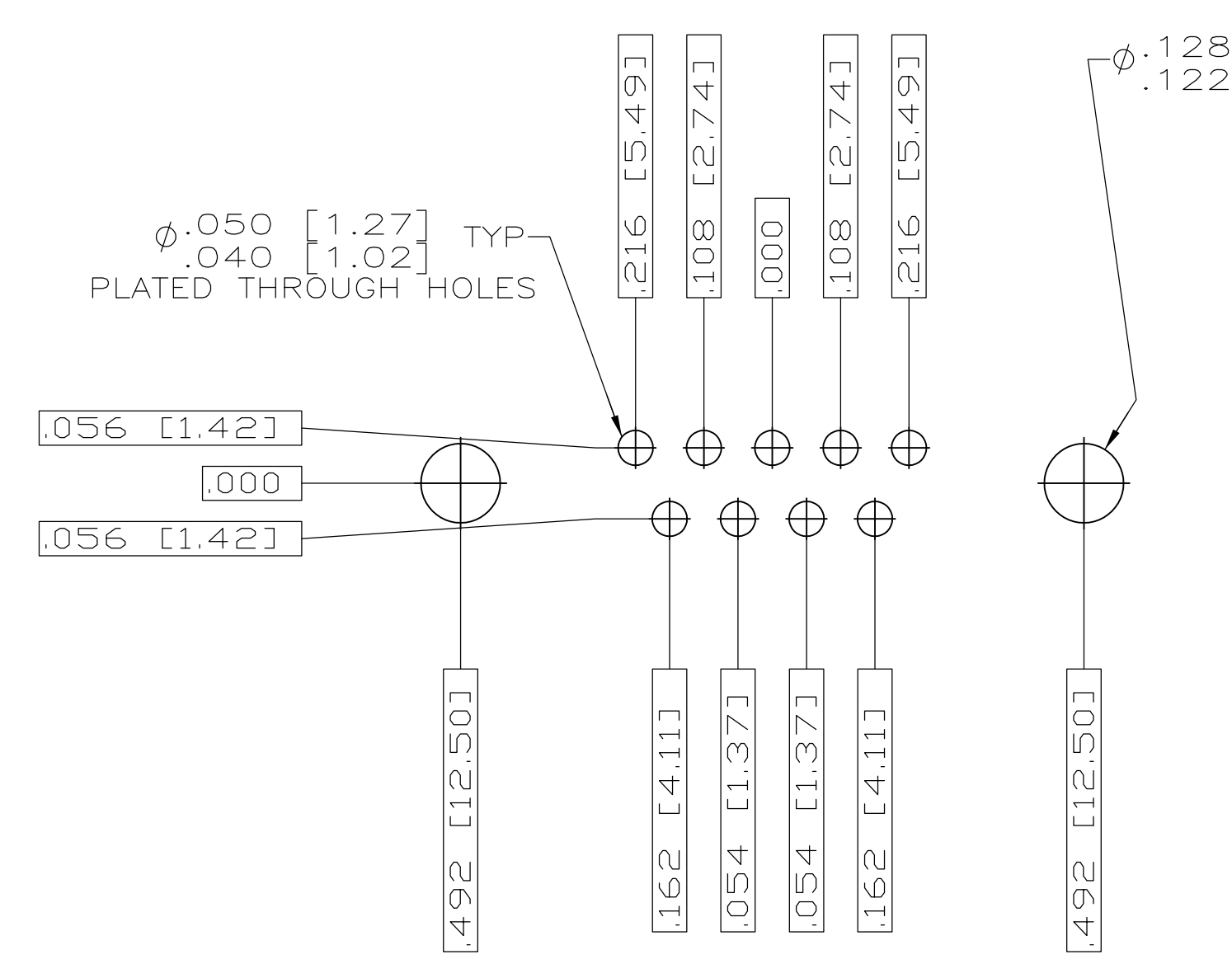

RECOMMENDED P.C. BOARD LAYOUT
SHELL SIZE 1 (9 POSITION) ⚠

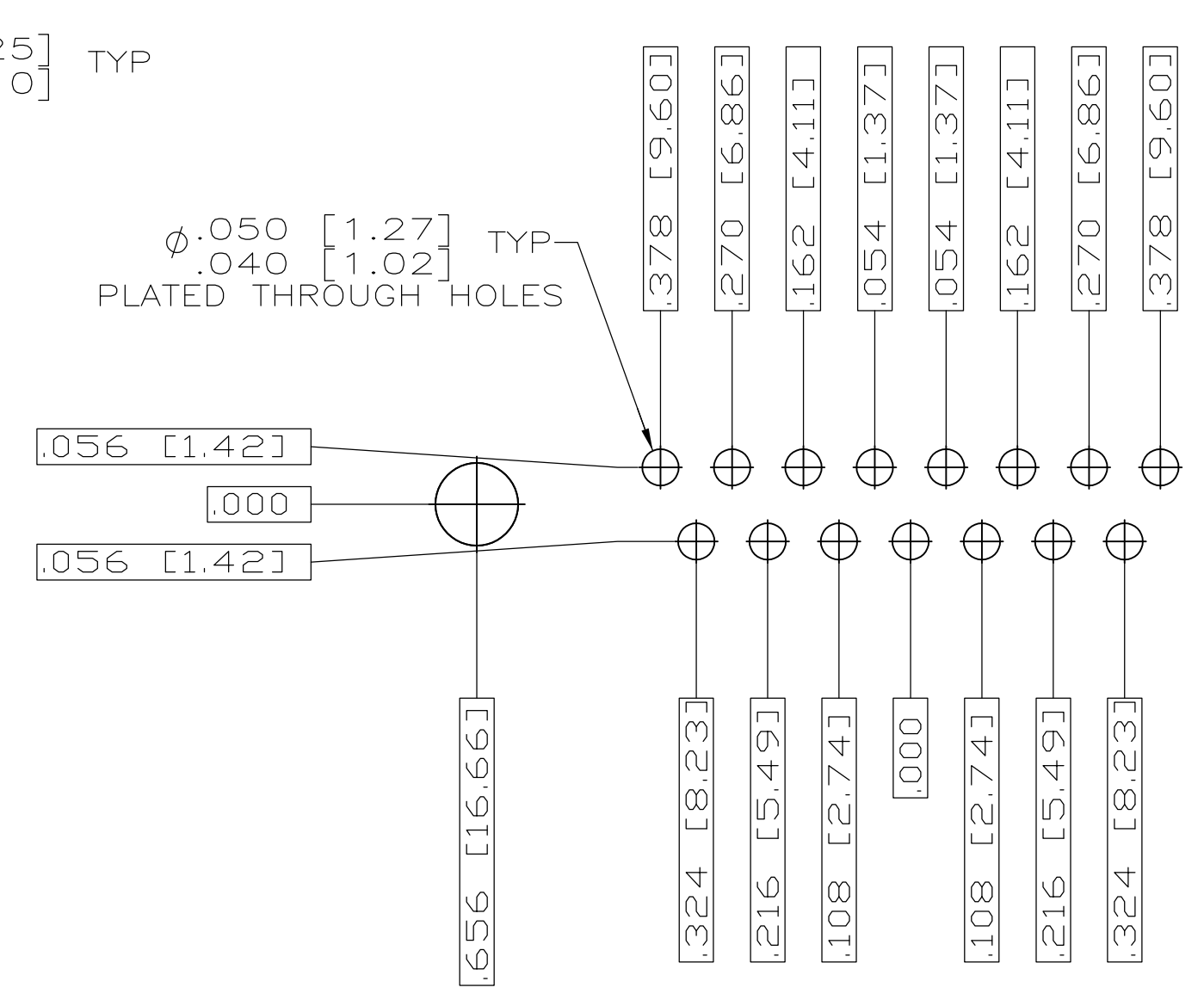

RECOMMENDED P.C. BOARD LAYOUT
SHELL SIZE 2 (15 POSITION) ⚠

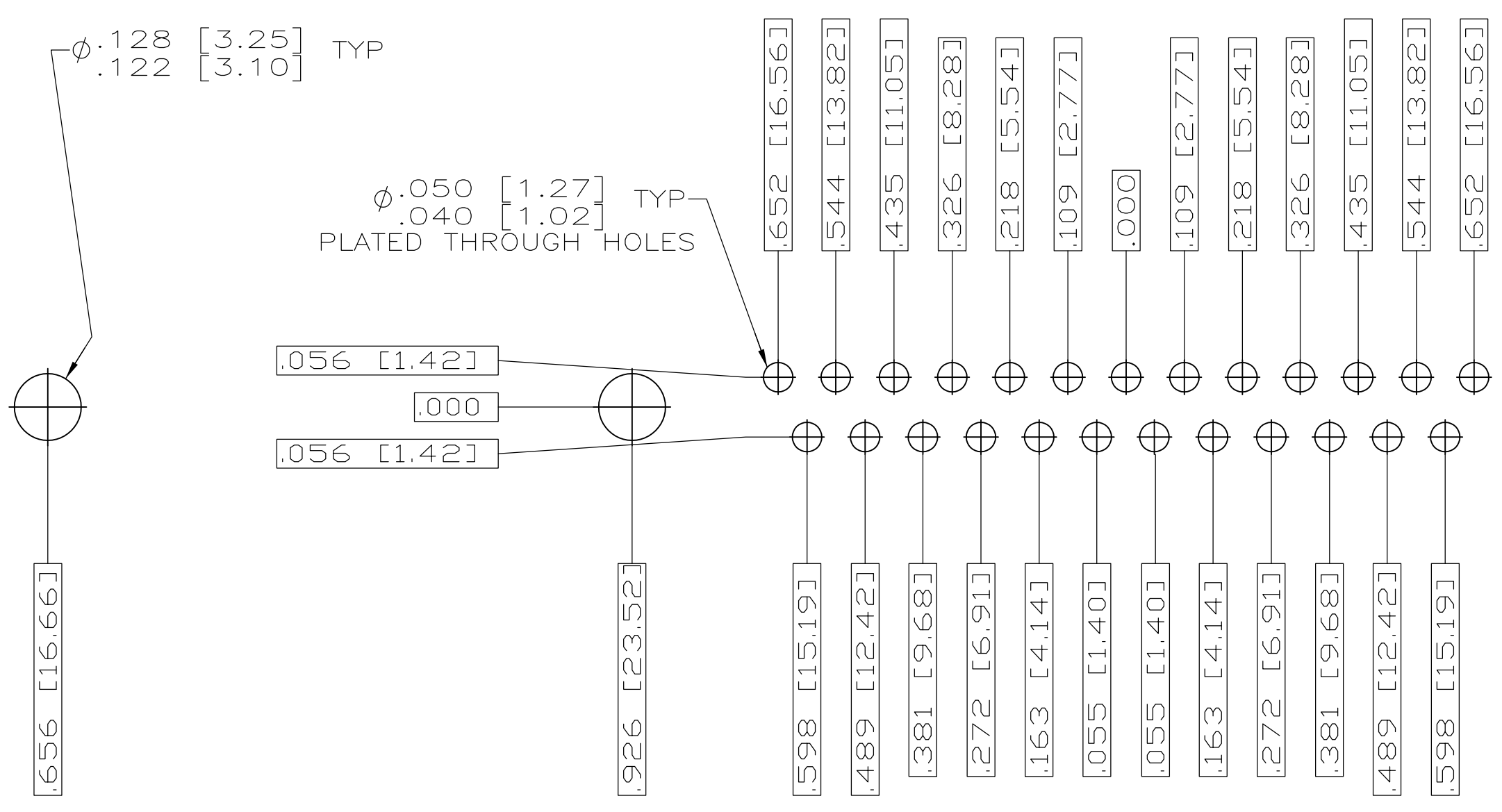

RECOMMENDED P.C. BOARD LAYOUT
SHELL SIZE 3 (25 POSITION) ⚠

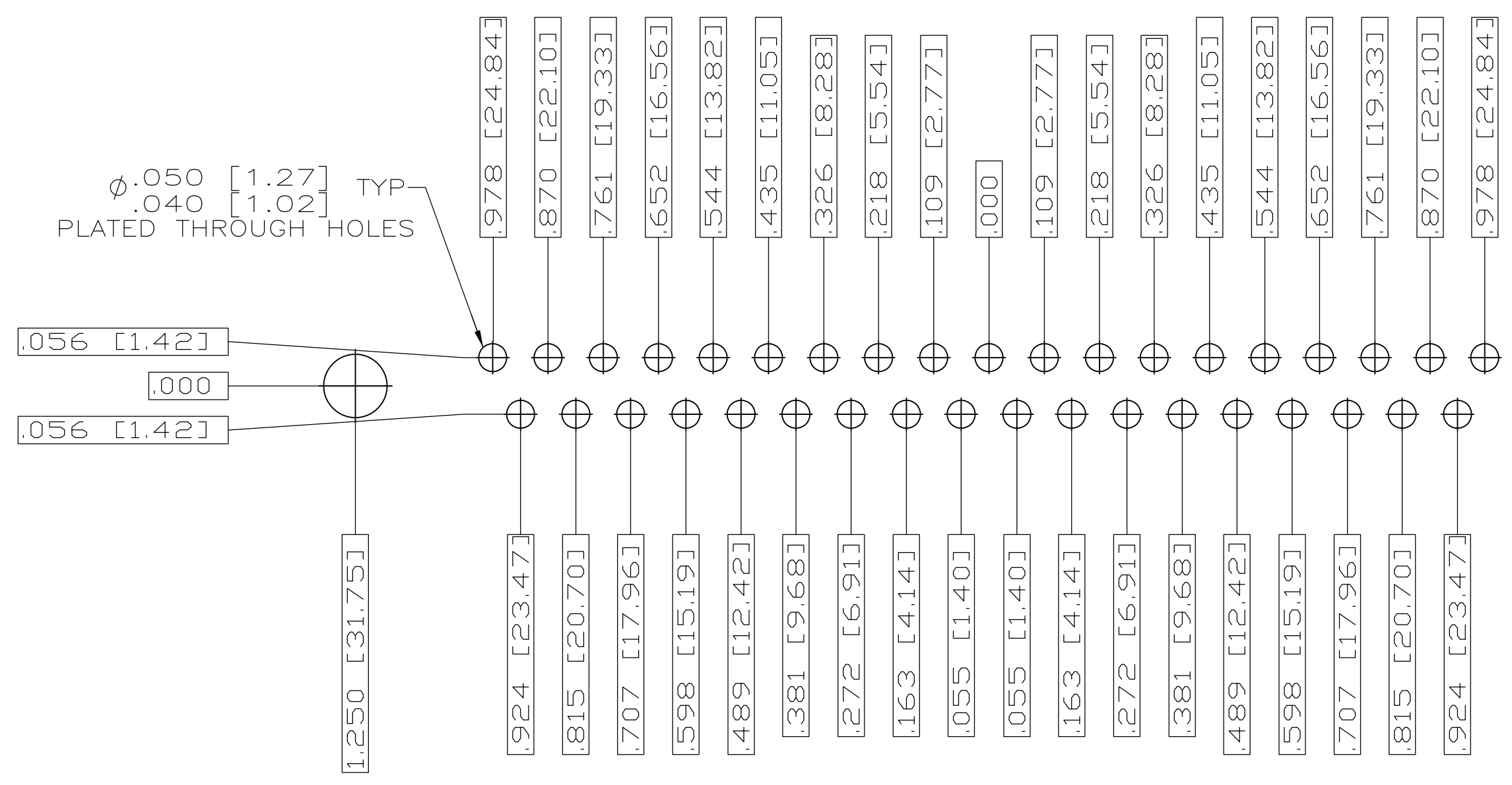

RECOMMENDED P.C. BOARD LAYOUT
SHELL SIZE 4 (37 POSITION) ⚠

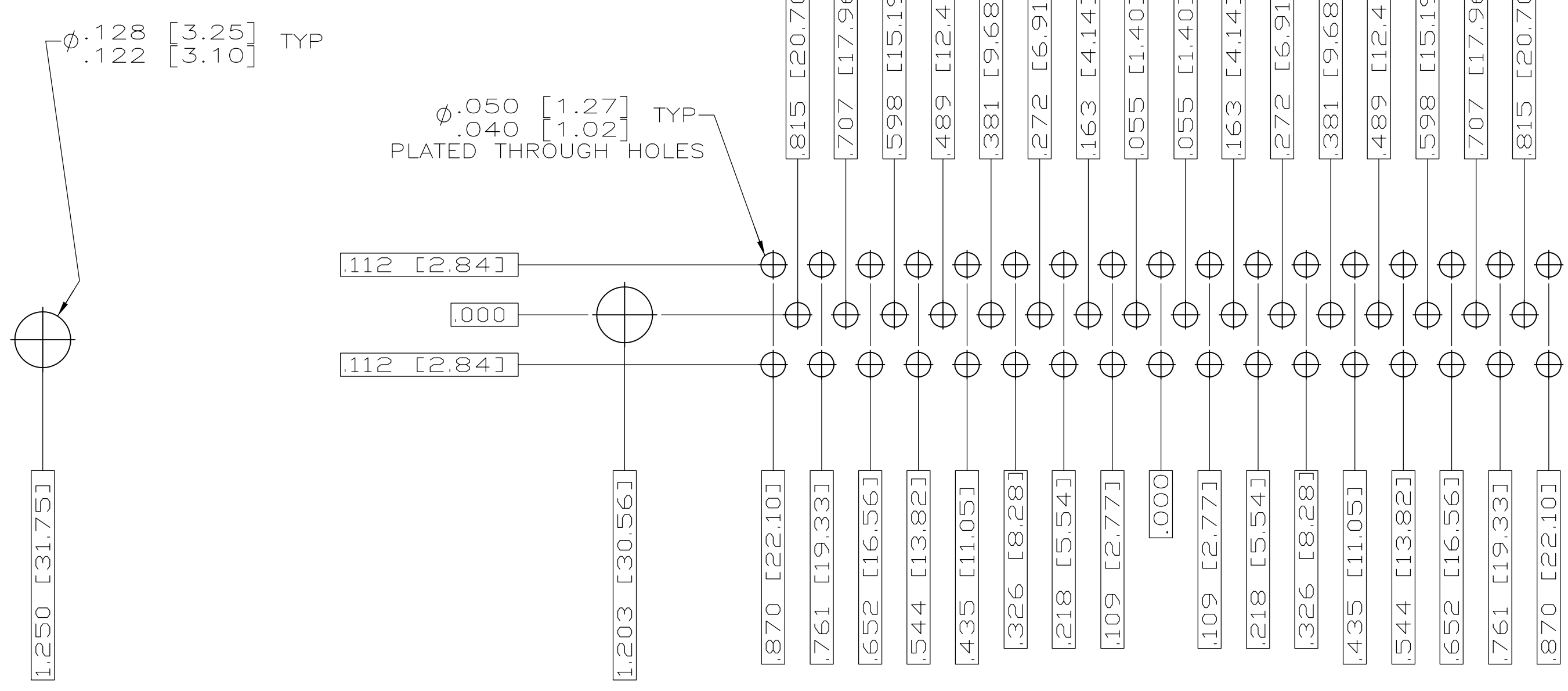

RECOMMENDED P.C. BOARD LAYOUT
SHELL SIZE 5 (50 POSITION) ⚠

THIS DRAWING IS A CONTROLLED DOCUMENT.		DN C.C.THOMAS	2-23-06	TE Connectivity
DIMENSIONS: INCHES		CHK D.HOFFMAN	2-23-06	
TOLERANCES UNLESS OTHERWISE SPECIFIED:		APVD D.MILLER	2-23-06	NAME PLUG ASSY,AMPLIMITE RIGHT ANGLE,SERIES 109,SIZE 1 THRU 5
0 PL ± 1 PL ± 2 PL ± 3 PL ± 4 PL ± ANGLES ± °		APPLICATION SPEC SIZE CAGE CODE DRAWING NO WEIGHT CUSTOMER DRAWING		RESTRICTED TO A1 00779 SCALE 4:1 SHEET 2 OF 2 REV B