

DESCRIPTION: FEMALE - DIP SOLDER / MACHINED - ECONOMY

No. OF PINS	DIMENSIONS							
	A	B	C	D	E	F	G	H
9	1.213	0.984	0.642	0.311	0.236	0.756	0.496	0.427
	30.80	24.99	16.30	7.90	5.99	19.20	12.60	10.85
15	1.541	1.312	0.970	0.311	0.236	1.091	0.496	0.427
	39.15	33.32	24.65	7.90	5.99	27.70	12.60	10.85
25	2.087	1.852	1.512	0.311	0.236	1.618	0.496	0.427
	53.00	47.04	38.40	7.90	5.99	41.10	12.60	10.85
37	2.728	2.500	2.157	0.311	0.236	2.256	0.496	0.427
	69.30	63.50	54.80	7.90	5.99	57.30	12.60	10.85
50	2.638	2.406	2.055	0.429	0.240	2.169	0.602	0.527
	67.00	61.11	52.20	10.90	6.10	55.10	15.30	13.39

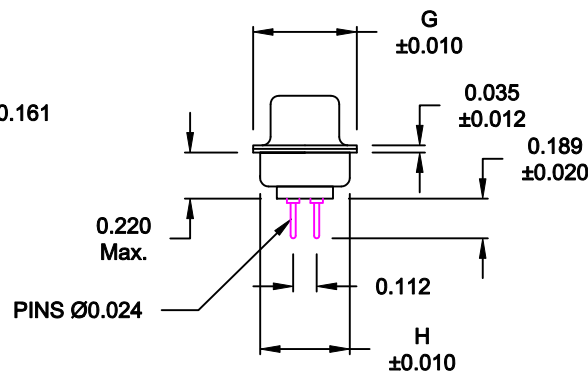
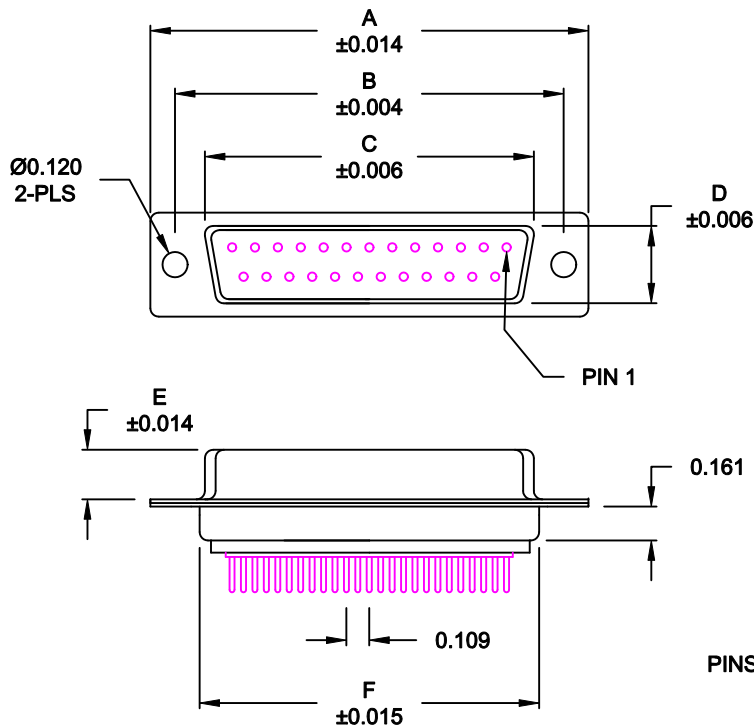

172-EYY-21YRYY1

- SERIES _____
- POSITIONS _____
- E09
 - E15
 - E25
 - E37
 - E50
- GENDER _____
- 2 = FEMALE
- TERMINATION _____
- 1 = DIP SOLDER
- SHELL PLATING _____
- 3 = NICKEL
 - 2 = TIN
- RoHS COMPLIANT _____
- HARDWARE OPTIONS _____
- 00 = NO HARDWARE
 - 01 = .098" CLINCH NUT (BOARD SIDE)
 - 02 = .236" CLINCH NUT (BOARD SIDE)
 - 03 = .236" CLINCH NUT (MOUNTING SIDE)
 - 05 = .237" 4-40 BOARD LOCK
 - 08 = .228" 4-40 BOARD LOCK
 - 90 = .237" 4-40 BOARD LOCK FOR 0.093" BOARD MAX.
 - 91 = .237" 4-40 SPACER/ BOARD LOCK
 - 92 = .237" 4-40 SPACER/ BOARD LOCK FOR 0.093" BOARD MAX.
- PLATING OPTIONS _____
- 1 = GOLD FLASH
 - 2 = 30MICRO-INCH GOLD
 - 5 = 15 MICRO-INCH GOLD

MATERIAL:

SHELL: STEEL, NICKEL OR TIN PLATED
 INSULATOR: UL 94V-O RATED, WHITE, PA6T
 PROCESS TEMP.: 260° PROCESS TEMPERATURE
 CONTACT: BRASS

ELECTRICAL:

CURRENT RATING: 5 AMPS
 CONTACT RESISTANCE: 15 mOhms Max.
 INSULATION RESISTANCE: 1,000 MOhms min.
 VOLTAGE: 500VAC FOR 1 MINUTE
 TEMPERATURE: -50° C TO 100° C

DO NOT SCALE FROM DRAWING

	THESE DRAWINGS AND SPECIFICATIONS ARE THE PROPERTY OF NorComp AND SHALL NOT BE REPRODUCED, COPIED OR USED AS THE BASIS FOR THE MANUFACTURE OF SALE OF APPARATUS WITHOUT WRITTEN PERMISSION.		DRAWN: PAM JENKINS	DATE: 11-28-05
			CHECKED:	DATE:
NorComp		SCALE: 1 : 1	SHEET 1	OF 3
		DWG NO. 172-EYY-21YRYY1		

RoHS COMPLIANT

DESCRIPTION: PCB LAYOUT - STANDARD "D" - MALE & FEMALE

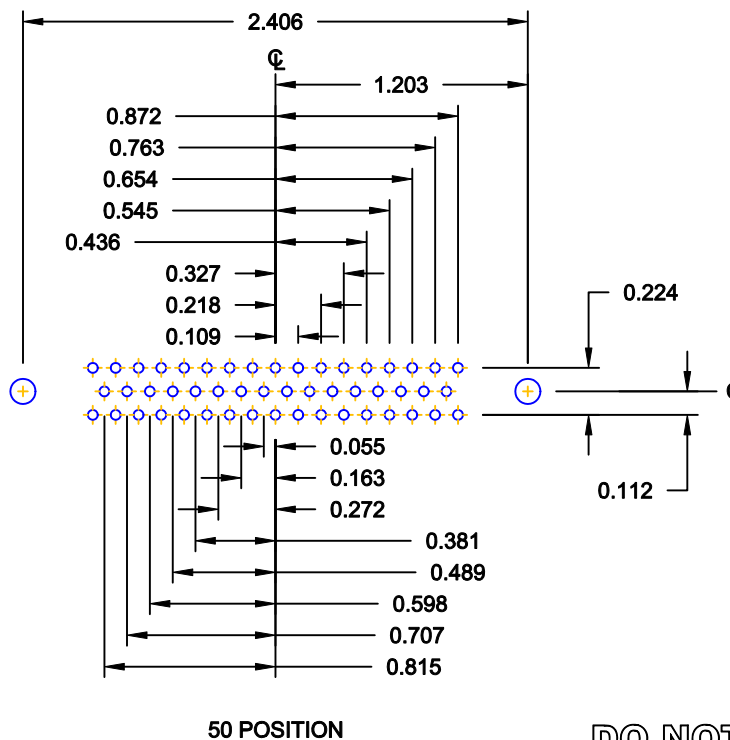
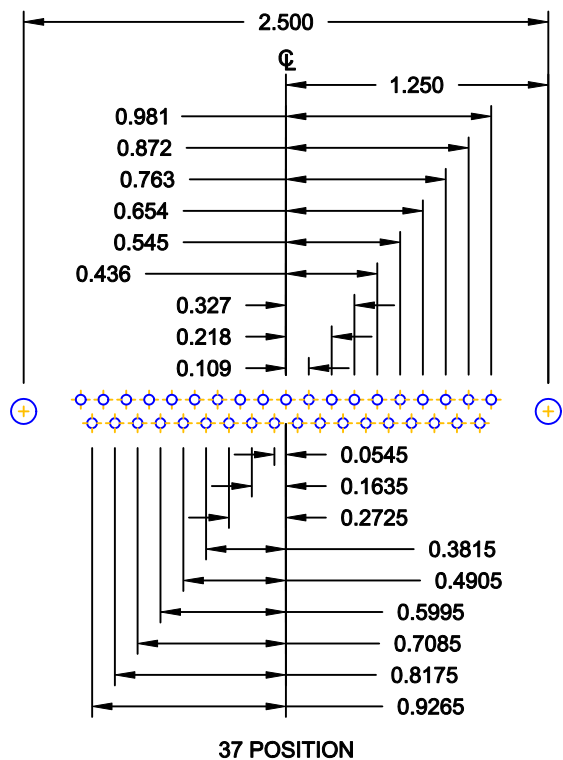
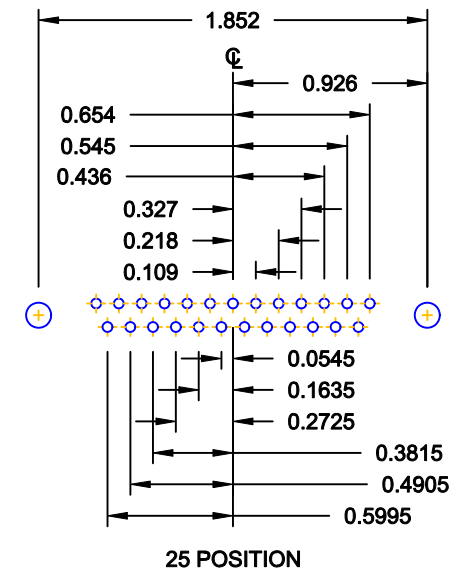
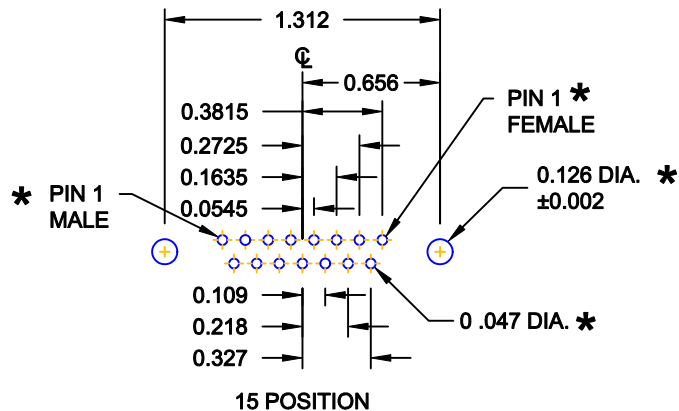
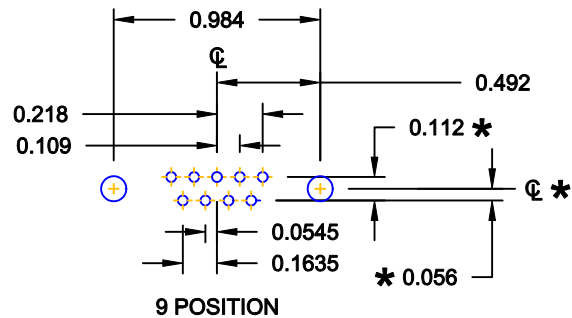

* TYP. ON ALL SIZES

DO NOT SCALE FROM DRAWING



THESE DRAWINGS AND SPECIFICATIONS ARE THE PROPERTY OF NorComp AND SHALL NOT BE REPRODUCED, COPIED OR USED AS THE BASIS FOR THE MANUFACTURE OF SALE OF APPARATUS WITHOUT WRITTEN PERMISSION.

DRAWN: C. SMITH		DATE: 03-08-06	
CHECKED:		DATE:	
SCALE: FULL	SHEET 2	OF 3	REV 14
DWG NO. 172-EYY-21YRY1			

NorComp

ALL CLINCH-NUTS ARE 4-40 INTERNAL THREADS

TOLERANCE:
ALL DIMENSIONS ARE ±0.010

01X 0.098" (BOARD SIDE) - CN1

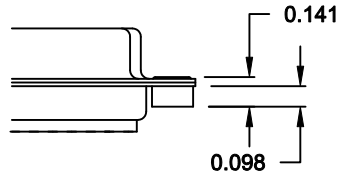

02X 0.236" (BOARD SIDE) - CN2

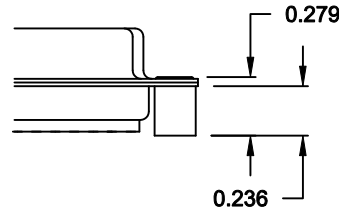

03X..... 0.236" (MATING SIDE) - CN8

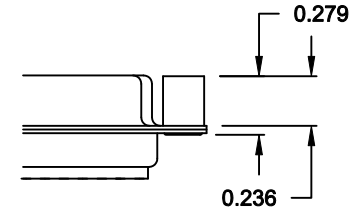

05X 0.237" (BOARD SIDE) - CN10

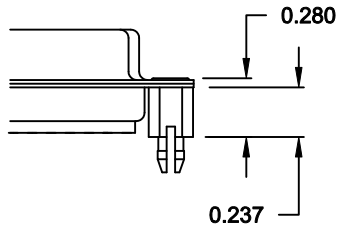

08X 0.228" (BOARD SIDE) - CN3

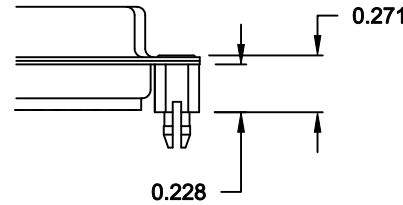

91X 0.237" BOARD SIDE
0.197 MATING SIDE
CN10/SFSO4404

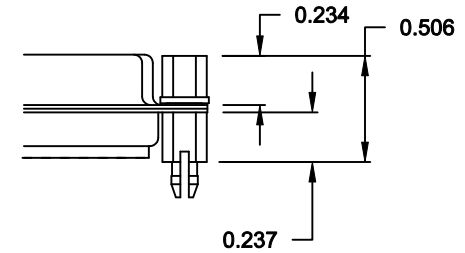

NOTE: 4-40 FEMALE SCREW LOCK IS REMOVABLE

90X 0.237" (BOARD SIDE) - CN10-237-093

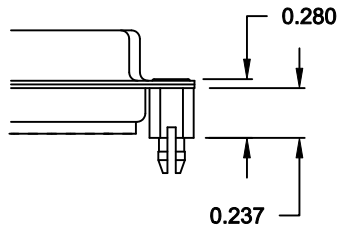

92X 0.237" BOARD SIDE
0.197 MATING SIDE
CN10-237-093/SFSO4404

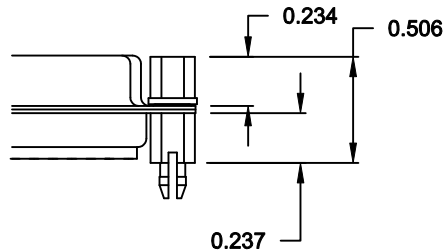

NOTE: 4-40 FEMALE SCREW LOCK IS REMOVABLE

NOTE: 90 & 92 OPTION FOR 0.093" MAX. BOARD THICKNESS

DO NOT SCALE FROM DRAWING

RoHS COMPLIANT

	THESE DRAWINGS AND SPECIFICATIONS ARE THE PROPERTY OF NorComp AND SHALL NOT BE REPRODUCED, COPIED OR USED AS THE BASIS FOR THE MANUFACTURE OF SALE OF APPARATUS WITHOUT WRITTEN PERMISSION.		DRAWN: WAYNE ROBBINS	DATE: 11-28-05
			CHECKED:	DATE:
NorComp		SCALE:	SHEET 3 OF 3	REV 14
		DWG NO. 172-EYY-21YRY1		