

**PRODUCT SPECIFICATION
FOR GIGABIT MAGNETIC JACK LED CONNECTOR**

SCOPE

This specification defines the mechanical and electrical characteristics of the Molex 85728 Series Gigabit Magnetic Jack 2x6 LED and for the 85727 Series Gigabit Magnetic Jack 2x4 LED.

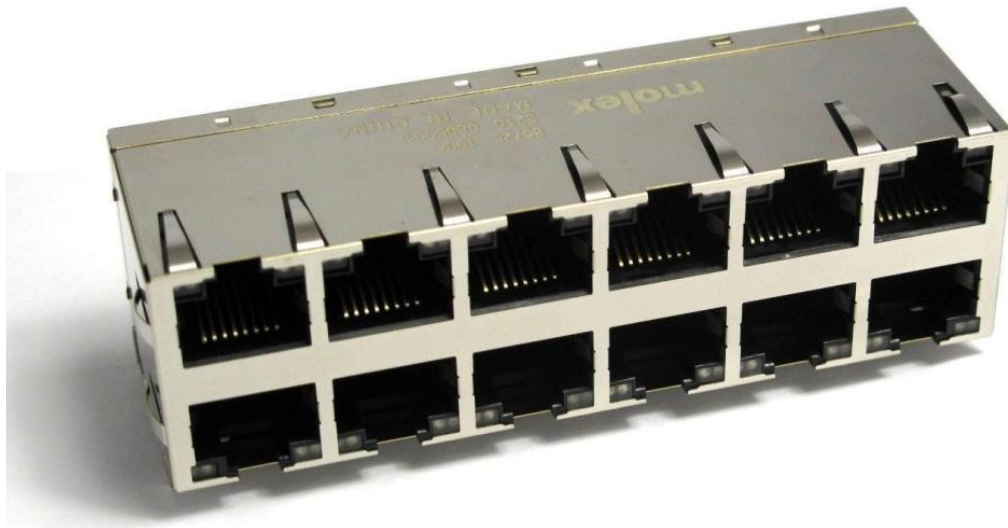

REVISION: B	ECR/ECN INFORMATION: EC No: IPG2016-0349 DATE: 14.04.2016	TITLE: PRODUCT SPECIFICATION GIGABIT MAGNETIC JACK LED 2x6, 2x4	SHEET No. 1 of 23
DOCUMENT NUMBER: PS-85728-001	CREATED / REVISED BY: J. Bader / T. Greulich / P. Butschbach	CHECKED BY: S. Steinke	APPROVED BY:

CONTENTS

1. PRODUCT DESCRIPTION 3

1.1. INTRODUCTION..... 3

1.2. SERIES AND PART NUMBERS..... 3

1.3. FEATURES..... 4

1.4. RELATED DOCUMENTATION 4

2. Ethernet Terminal Details 5

2.1. ETHERNET TERMINAL PINOUT..... 5

2.2. MAGNETIC WIRING SCHEMATIC DIAGRAM 6

2.3. PIN FUNCTIONS 7

2.4. ELECTRICAL CHARACTERISTICS AT 25°C, UNLESS OTHERWISE NOTED 7

2.5. TRANSMISSION PERFORMANCE AT 25°C 8

3. RJ-45 Contact and Port Detail 12

3.1. RJ-45 CONTACT (CABLE INTERFACE) ARRANGEMENT 12

3.2. CONTACT FUNCTIONS 12

3.3. TRANSMISSION PERFORMANCE, WIRING SCHEMATIC DIAGRAM..... 12

3.4. LED TERMINAL DETAIL..... 13

3.5. LED TERMINAL PINOUT..... 13

3.6. ELECTRICAL LED CHARACTERISTICS 15

APPENDICES 16

APPENDIX A:MECHANICAL AND ENVIRONMENTAL REQUIREMENTS 16

APPENDIX B:ENVIRONMENTAL REQUIREMENTS..... 18

APPENDIX C:STANDARDS AND NORMATIVE REFERENCES..... 19

APPENDIX D:TEST REQUIREMENT ADDITIONAL TO POETEC..... 20

APPENDIX E:TEST SEQUENCE 21

APPENDIX F: ROHS COMPLIANCE / SAFETY APPROVAL 22

APPENDIX G:HANDLING AND STORAGE..... 22

REVISION: B	ECR/ECN INFORMATION: EC No: IPG2016-0349 DATE: 14.04.2016	TITLE: PRODUCT SPECIFICATION GIGABIT MAGNETIC JACK LED 2x6, 2x4	SHEET No. 2 of 23
DOCUMENT NUMBER: PS-85728-001		CREATED / REVISED BY: J. Bader / T. Greulich / P. Butschbach	CHECKED BY: S. Steinke
		APPROVED BY:	

1. PRODUCT DESCRIPTION

1.1. Introduction

The Gigabit Magnetic Jack is designed for easy implementation by meeting standard footprint and panel cut-outs for industry wide adoption in accordance with PoETeC ICM).

1.2. Series and Part Numbers

This Product Specification covers the 85728 and 85727 series of Stacked/Ganged Gigabit connectors (with exemption of 85727 Magnetic Jack GND isolation). Both series differ in the number of RJ-45 ports and amount of LEDs.

For a list of all part numbers and options, please refer to the related Sales Drawings (see chapter 1.4).

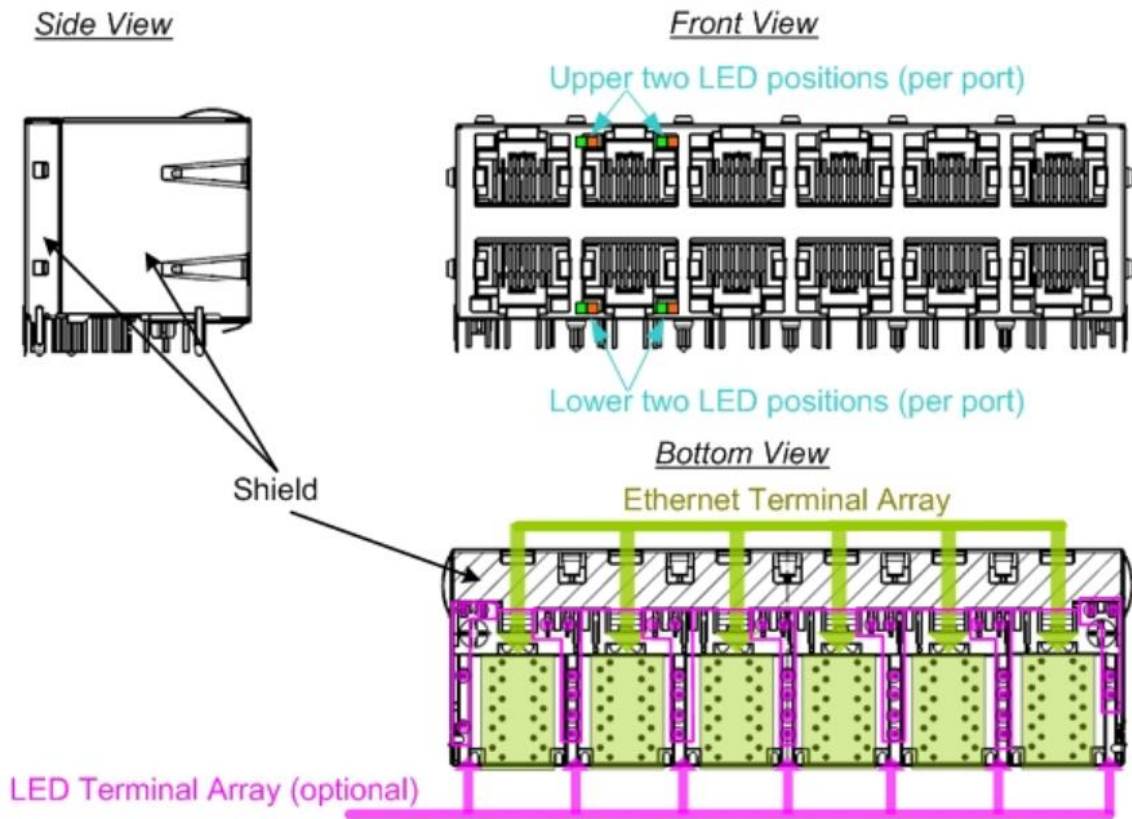

Figure 1 View of Gigabit Magnetic Jack 2x6 port version PN:85728-xxx
See Sales Drawing for detailed dimensions and options

REVISION: B	ECR/ECN INFORMATION: EC No: IPG2016-0349 DATE: 14.04.2016	TITLE: PRODUCT SPECIFICATION GIGABIT MAGNETIC JACK LED 2x6, 2x4	SHEET No. 3 of 23
DOCUMENT NUMBER: PS-85728-001	CREATED / REVISED BY: J. Bader / T. Greulich / P. Butschbach	CHECKED BY: S. Steinke	APPROVED BY:

1.3. Features

- Fully shielded RJ-45 connector with multiple ports
 - Integrated Ethernet magnetics with Bob Smith termination with isolation capacitor
 - Compatible with a variety of Gigabit Ethernet transceiver ICs (PHY's)
 - Compliant with Gigabit (1000 Base-T) IEEE STD 802.3-2012
 - Connector intended to be mated with plugs according IEC 60603-7
 - Dielectric isolation of 2250VDC between PHY pins and cable side
- LED's are optional, (For a list of all part numbers, please refer to the related Sales Drawings (see chapter 1.4).
- Operating temperature commercial version: 0°C to 70°C, external ambient temperature
 - Operating temperature industrial version: -40°C to 85°C, external ambient temperature

1.4. Related Documentation

MOLEX Sales Drawings and Packaging Specifications:

See the appropriate Sales Drawings for information on dimensions, materials, plating and marking, LED options..

Series	Description	Sales Drawing	Packaging Specification
85728	Versions with 12 RJ-45 ports and different LED options	SD-85728-xxx	PK-85728-001
85727	Versions with 8 RJ-45 ports and different LED options	SD-85727-xxx	PK-85727-001

PoETeC V2: Power over Ethernet Technology Consortium

This consortium specifies dimensions and characteristics for stacked ganged RJ45 magnetic jacks including integrated and Enabled Power over Ethernet functionality.

For further information please contact Molex

Normative references:

- IEEE 802.3
- IEC 60603-7, 60603-7-1, IEC 62471, TIA-1096-A

B	REVISION:	ECR/ECN INFORMATION:	TITLE:	PRODUCT SPECIFICATION GIGABIT MAGNETIC JACK LED 2x6, 2x4	SHEET No.
		EC No: IPG2016-0349			4 of 23
		DATE: 14.04.2016			
DOCUMENT NUMBER:			CREATED / REVISED BY:	CHECKED BY:	APPROVED BY:
PS-85728-001			J. Bader / T. Greulich / P. Butschbach	S. Steinke	

2. Ethernet Terminal Details

The following section details the functional, mechanical and electrical characteristics of the Ethernet terminal on the Gigabit Magnetic Jack.

2.1. Ethernet Terminal Pinout

The pin-out for the Ethernet Terminals on the module is shown below (12-port version).

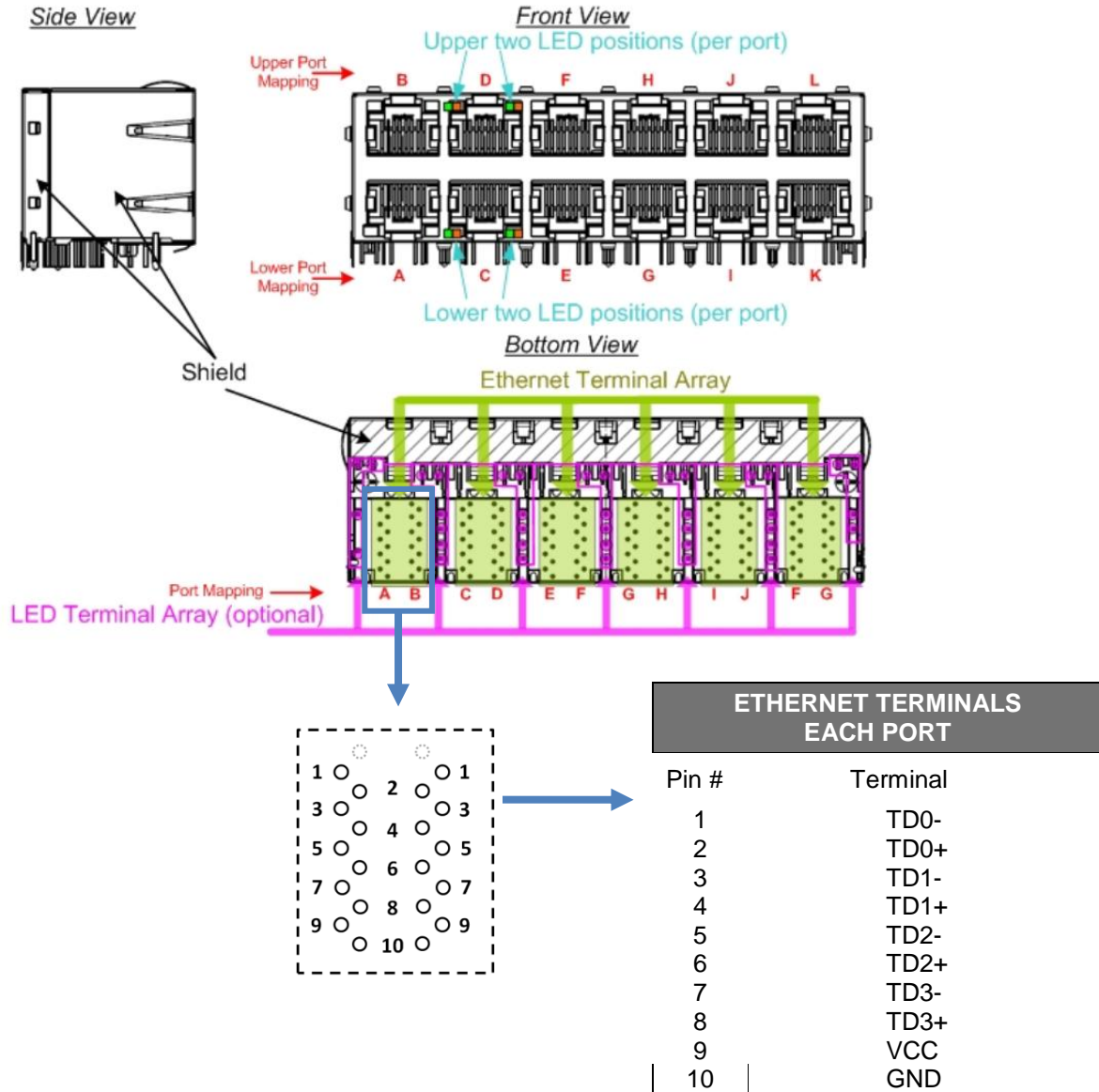

Figure 2 Ethernet terminals and mapping of port to terminal (85727 series only port A to H)
Bottom view: See Sales Drawings for detailed dimensions and PCB layout view

REVISION: B	ECR/ECN INFORMATION: EC No: IPG2016-0349 DATE: 14.04.2016	TITLE: PRODUCT SPECIFICATION GIGABIT MAGNETIC JACK LED 2x6, 2x4	SHEET No. 5 of 23
DOCUMENT NUMBER: PS-85728-001	CREATED / REVISED BY: J. Bader / T. Greulich / P. Butschbach	CHECKED BY: S. Steinke	APPROVED BY:

2.2. Magnetic Wiring Schematic Diagram

The following is the magnetic wiring schematic diagram for the Ethernet terminals on the Gigabit Magnetic Jack.

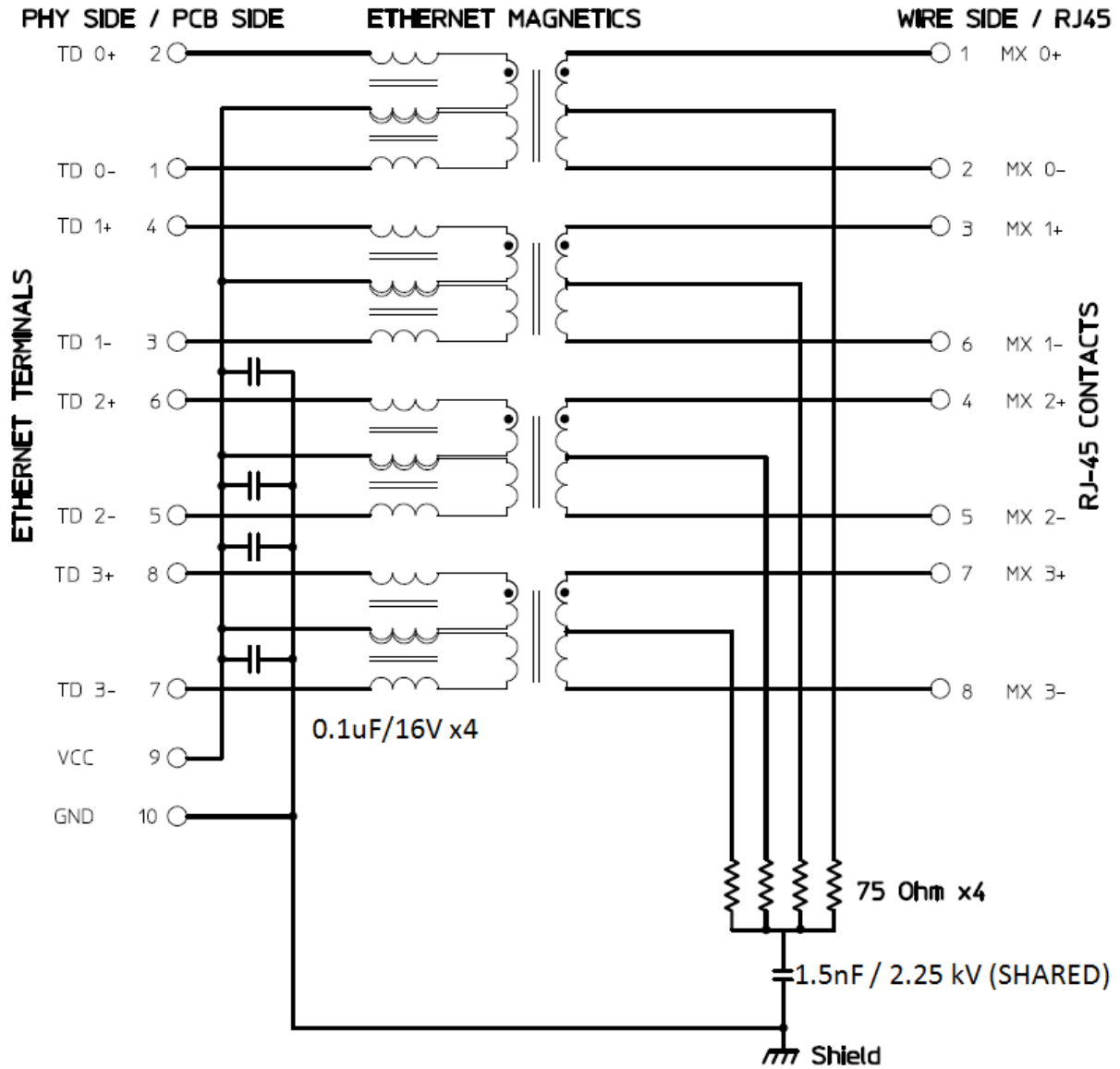

Figure 3 Ethernet magnetic wiring schematic diagram (one port shown)

REVISION: B	ECR/ECN INFORMATION: EC No: IPG2016-0349 DATE: 14.04.2016	TITLE: PRODUCT SPECIFICATION GIGABIT MAGNETIC JACK LED 2x6, 2x4	SHEET No. 6 of 23
DOCUMENT NUMBER: PS-85728-001	CREATED / REVISED BY: J. Bader / T. Greulich / P. Butschbach	CHECKED BY: S. Steinke	APPROVED BY:

2.3. Pin Functions

The following table contains the pin function descriptions for the Ethernet terminals on the Gigabit Magnetic Jack (one port).

Pin #	Ethernet signal	I/O	Description
1	TD0-	I/O	Gigabit Ethernet data (negative polarity).
2	TD0+	I/O	Gigabit Ethernet data (positive polarity).
3	TD1-	I/O	Gigabit Ethernet data (negative polarity).
4	TD1+	I/O	Gigabit Ethernet data (positive polarity).
5	TD2-	I/O	Gigabit Ethernet data (negative polarity).
6	TD2+	I/O	Gigabit Ethernet data (positive polarity).
7	TD3-	I/O	Gigabit Ethernet data (negative polarity).
8	TD3+	I/O	Gigabit Ethernet data (positive polarity).
9	VCC	n/a	V _{cc} supply of the Ethernet PHY.
10	GND	n/a	Ground of the Ethernet PHY.

2.4. Electrical Characteristics at 25°C, unless otherwise noted

The following tables contain the electrical characteristics and transmission performance for the Ethernet terminals on the Gigabit Magnetic Jack.

Parameter	Test Condition	Min	Typ	Max	Units
HiPot isolation (see note)	PHY side (Ethernet terminals, LED terminals, shield)	2250			V DC
	to cable side (RJ-45-contacts) for 1min. Requirement: Leakage Current <1mA	(1500)			V AC
Isolation Resistance after 10 HiPot Pulses*	10/700µs 1500V (IEC 60950-1)	>40			MOhm
OCL	With 8mA BIAS at 100kHz, 100mV (Temperature range specified in related SD)	350			µH

Note: The module includes several capacitors that are charged during the performance of a HiPot test. Using an AC HiPot test will show a high reactive current (due to capacitance), which could mask an abnormally high insulation leakage. This high reactive current might also overload the HiPot test equipment. Therefore a DC test setup is strongly recommended.

Properly discharge the device under test after the test has been performed.

* Compliance verification can be completed by analysis versus actual measurements.

REVISION: B	ECR/ECN INFORMATION: EC No: IPG2016-0349 DATE: 14.04.2016	TITLE: PRODUCT SPECIFICATION GIGABIT MAGNETIC JACK LED 2x6, 2x4	SHEET No. 7 of 23
DOCUMENT NUMBER: PS-85728-001	CREATED / REVISED BY: J. Bader / T. Greulich / P. Butschbach	CHECKED BY: S. Steinke	APPROVED BY:

2.5. Transmission Performance at 25°C

Insertion Loss [dB max.]²	
Frequency [MHz]	LIMITS
1.0-9.9	$-(0.4+0.1*\log(F))$
10.0-49.9	$-(0.5+0.3*\log(F/10))$
50.0-79.9	$-(1+1.4*\log(F/80))$
80.0-99.9	$-(1.3+3*\log(F/100))$
100.0-199.9	$-(4+9*\log(F/200))$
Values below provided for information only	
1	-0.4
10	-0.5
50	-0.7
80	-1.0
100	-1.3
200	-4

Return Loss [dB min.]³	
Frequency [MHz]	LIMITS
1.0-9.9	-27
10.0-49.9	$-(27-17*\log(F/10))$
50.0-79.9	$-(27-17*\log(F/10))$
80.0-99.9	$-(27-17*\log(F/10))$
100.0-199.9	$-(1-30*\log(F/200))$
Values below provided for information only	
1	-27
10	-27
50	-15
80	-12
100	-10
200	-1

REVISION: B	ECR/ECN INFORMATION: EC No: IPG2016-0349 DATE: 14.04.2016	TITLE: PRODUCT SPECIFICATION GIGABIT MAGNETIC JACK LED 2x6, 2x4	SHEET No. 8 of 23
DOCUMENT NUMBER: PS-85728-001	CREATED / REVISED BY: J. Bader / T. Greulich / P. Butschbach	CHECKED BY: S. Steinke	APPROVED BY:

NEXT [dB min.]⁴	
Frequency [MHz]	LIMITS
1.0-9.9	-(66-21*log(F))
10.0-49.9	-(45-16*log(F/10))
50.0-79.9	-(25-30*log(F/100))
80.0-99.9	-(25-30*log(F/100))
100.0-199.9	-(20-16.5*log(F/200))
Values below provided for information only	
1	-66
10	-45
50	-34
80	-27.9
100	-25
200	-20

CM-DM [dB min.]¹	
Frequency [MHz]	LIMITS
1.0-9.9	-(48-12*log(F))
10.0-59.9	-(36-7.8*log(F/10))
60.0-79.9	-(18-54*log(F/100))
80.0-99.9	-(18-54*log(F/100))
100.0-199.9	-(8.7-15.5*log(F/400))
200.0-399.9	-(8.7-15.5*log(F/400))
400.0-1000.0	-(4.5-10.5*log(F/1000))
Values below provided for information only	
1	-48
10	-36
50	-30.5
80	-23.2
100	-18
200	-13.5
400	-9
1000	-4.5

REVISION: B	ECR/ECN INFORMATION: EC No: IPG2016-0349 DATE: 14.04.2016	TITLE: PRODUCT SPECIFICATION GIGABIT MAGNETIC JACK LED 2x6, 2x4	SHEET No. 9 of 23
DOCUMENT NUMBER: PS-85728-001	CREATED / REVISED BY: J. Bader / T. Greulich / P. Butschbach	CHECKED BY: S. Steinke	APPROVED BY:

DM-CM [dB min.]²	
Frequency [MHz]	LIMITS
1.0-9.9	-(54.5-14.5*log(F))
10.0-49.9	-25
50.0-79.9	-25
80.0-99.9	-25
100.0-199.9	-(9-23*log(F/500))
200.0-499.9	-(9-23*log(F/500))
500.0-1000.0	-(6-10*log(F/1000))
Values below provided for information only	
1	-54.5
10	-25
50	-25
80	-25
100	-25
200	-18.2
400	-11.2
1000	-6

REVISION: B	ECR/ECN INFORMATION: EC No: IPG2016-0349 DATE: 14.04.2016	TITLE: PRODUCT SPECIFICATION GIGABIT MAGNETIC JACK LED 2x6, 2x4	SHEET No. 10 of 23
DOCUMENT NUMBER: PS-85728-001	CREATED / REVISED BY: J. Bader / T. Greulich / P. Butschbach	CHECKED BY: S. Steinke	APPROVED BY:

CMR [dB min.]²	
Frequency [MHz]	LIMITS
1.0-9.9	-(57-23*log(F))
10.0-19.9	-(57-23*log(F))
20.0-79.9	-27
80.0-99.9	-(27-14.5*log(F/80))
100.0-199.9	-(27-14.5*log(F/80))
200.0-399.9	-(21.5-39*log(F/200))
400.0-1000.0	-10
Values below provided for information only	
1	-57
10	-34
50	-27
80	-27
100	-25.5
200	-21.5
400	-10
1000	-10

- 1 = Measurements made from Cable side to PHY side
- 2 = Measurements made from PHY side to Cable side
- 3 = Measurements made from Cable side to Cable side
- 4 = Measurements made from PHY side to PHY side

REVISION: B	ECR/ECN INFORMATION: EC No: IPG2016-0349 DATE: 14.04.2016	TITLE: PRODUCT SPECIFICATION GIGABIT MAGNETIC JACK LED 2x6, 2x4	SHEET No. 11 of 23
DOCUMENT NUMBER: PS-85728-001		CREATED / REVISED BY: J. Bader / T. Greulich / P. Butschbach	CHECKED BY: S. Steinke
		APPROVED BY:	

3. RJ-45 Contact and Port Detail

The following section details the functional, mechanical and electrical characteristics of the RJ-45 contacts (RJ-45 port) on the Gigabit Magnetic Jack.

3.1. RJ-45 Contact (Cable Interface) Arrangement

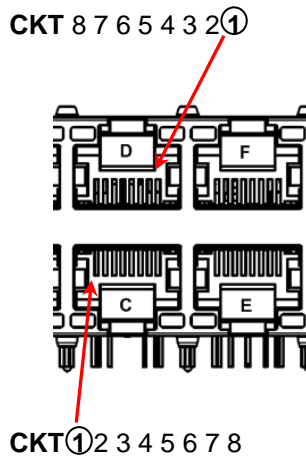

Figure 4 RJ-45 contacts (front view detail)

3.2. Contact Functions

Contact #	Ethernet signal	I/O	Description
			Ethernet Function
1	MX 0+	I/O	Gigabit Ethernet data (+)
2	MX 0-	I/O	Gigabit Ethernet data (-)
3	MX 1+	I/O	Gigabit Ethernet data (+)
4	MX 2+	I/O	Gigabit Ethernet data (+)
5	MX 2-	I/O	Gigabit Ethernet data (-)
6	MX 1-	I/O	Gigabit Ethernet data (-)
7	MX 3+	I/O	Gigabit Ethernet data (+)
8	MX 3-	I/O	Gigabit Ethernet data (-)

3.3. Transmission Performance, Wiring Schematic Diagram

For transmission performance, wiring schematic diagram, HiPot characteristics see information shown in sections 2.2 Magnetic Wiring Schematic Diagram, 2.4 Electrical Characteristics at 25°C and 2.5 Transmission Performance at 25°C.

REVISION: B	ECR/ECN INFORMATION: EC No: IPG2016-0349 DATE: 14.04.2016	TITLE: PRODUCT SPECIFICATION GIGABIT MAGNETIC JACK LED 2x6, 2x4	SHEET No. 12 of 23
DOCUMENT NUMBER: PS-85728-001	CREATED / REVISED BY: J. Bader / T. Greulich / P. Butschbach	CHECKED BY: S. Steinke	APPROVED BY:

3.4. LED Terminal Detail

The following section details the functional, mechanical and electrical characteristics of the LED terminals on the Gigabit Magnetic Jack.

3.5. LED Terminal Pinout

The Gigabit Magnetic Jack has on-board LEDs that can be controlled directly. Each port has up to two LED positions with up to two different colors (single or bi-colour) per position. The bi-colour LEDs are bipolar. Color change is achieved by reversing voltage using an external switch or relay.

Note: the LEDs need external current limitation and voltage adjustment according the LED-characteristics.

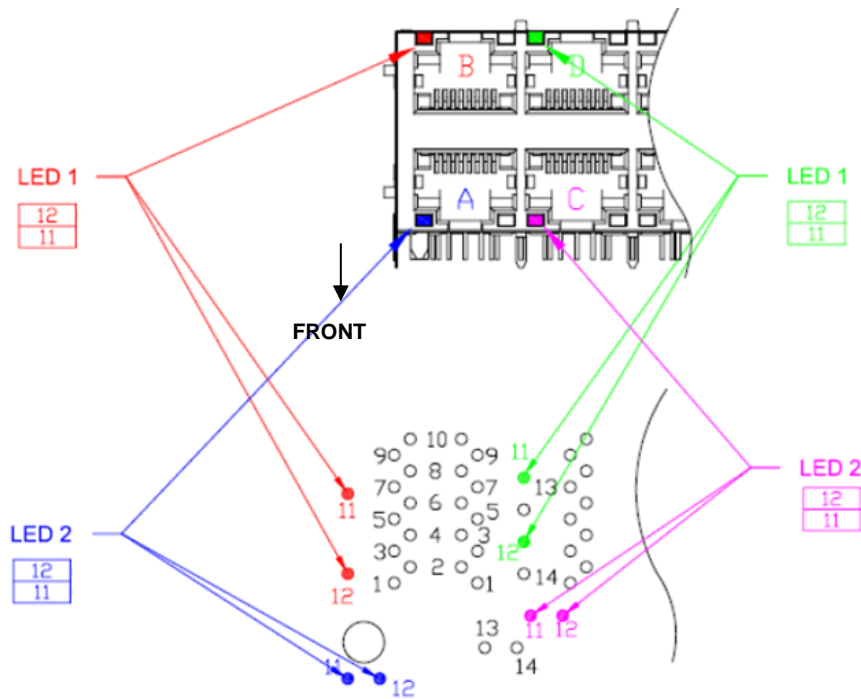

Figure 5 LED pin-out for left LED's for lower and upper ports
See Sales Drawing for detailed dimensions

REVISION: B	ECR/ECN INFORMATION: EC No: IPG2016-0349 DATE: 14.04.2016	TITLE: PRODUCT SPECIFICATION GIGABIT MAGNETIC JACK LED 2x6, 2x4	SHEET No. 13 of 23
DOCUMENT NUMBER: PS-85728-001	CREATED / REVISED BY: J. Bader / T. Greulich / P. Butschbach	CHECKED BY: S. Steinke	APPROVED BY:

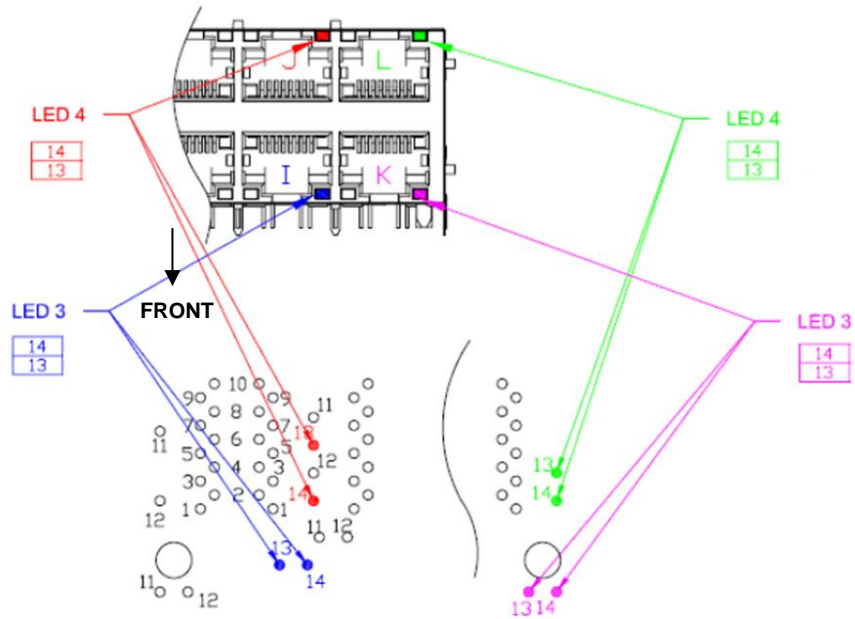

Figure 6 LED pin-out for right LED's for lower and upper ports
See Sales Drawing for detailed dimensions

REVISION: B	ECR/ECN INFORMATION: EC No: IPG2016-0349 DATE: 14.04.2016	TITLE: PRODUCT SPECIFICATION GIGABIT MAGNETIC JACK LED 2x6, 2x4	SHEET No. 14 of 23
DOCUMENT NUMBER: PS-85728-001	CREATED / REVISED BY: J. Bader / T. Greulich / P. Butschbach	CHECKED BY: S. Steinke	APPROVED BY:

3.6. Electrical LED Characteristics

The following table contains the electrical characteristics for the LED and LED terminals on the Gigabit Magnetic Jack.

All LEDs are low power LEDs according IEC 62471 /exempt group.

Parameter	Test Condition	Min	Max	Units
Intensity Orange LED	Measured at connector front with If=10mA / 25°C	5	10	mcd
Intensity Yellow LED	Measured at connector front with If=10mA / 25°C	5	10	mcd
Intensity Green LED	Measured at connector front with If=10mA / 25°C	5	10	mcd
Wavelength Orange LED	Dominant @ 20mA	600	621.5	nm
Wavelength Yellow LED	Dominant @ 20mA	580	595	nm
Wavelength Green LED	Dominant @ 20mA	560	575	nm
Forward Voltage Orange LED	@ 20mA	1.7	2.3	V
Forward Voltage Yellow LED	@ 20mA	2	2.5	V
Forward Voltage Green LED	@ 20mA	1.75	2.35	V
Forward Current Orange LED			25	mA
Forward Current Yellow LED			25	mA
Forward Current Green LED			25	mA

REVISION: B	ECR/ECN INFORMATION: EC No: IPG2016-0349 DATE: 14.04.2016	TITLE: PRODUCT SPECIFICATION GIGABIT MAGNETIC JACK LED 2x6, 2x4	SHEET No. 15 of 23
DOCUMENT NUMBER: PS-85728-001	CREATED / REVISED BY: J. Bader / T. Greulich / P. Butschbach	CHECKED BY: S. Steinke	APPROVED BY:

APPENDICES

Appendix A: Mechanical and Environmental requirements

PARAMETER	TEST CONDITION						SPECIFICATION REFERENCE	REQUIREMENT
Vibration: Operating Random Vibration	Frequency [Hz]	5-350		350-350			IEC 60068-2-64	
	Amplitude [g rms]	0.30		0.30				
	Duration [minutes]	10.00		10.00				
	Power Spectral Density [g ² /Hz]	0.0002		0.0001				
	σ [-]	3		3				
Vibration: Non-Operating Sinusoidal Vibration	Swept Sine: 5 to 500Hz resonant search 1 octave/minute sweep rate, 5-minute resonant dwell at 4 resonances per axis - 0.5 g (0-peak)						IEC 60068-2-6	
Vibration: Non-Operational Survival, Sinusoidal 10mins/axis	Frequency (Hz)	5-100	100-137	137-350	350-500	500	IEC 60068-2-64	No damage <20 milliohms increase from initial: Discontinuity: Not greater than 5 microseconds
	Amplitude (g rms)	2.41	2.41	2.41	2.41	2.41		
	Duration (minutes)	10.00	10.00	10.00	10.00	10.00		
	Slope (dB/Octave)	0.00	-6.00	0.00	-6.00	-		
	Power Spectral Density (g ² /Hz)	0.015	-	0.0080	-	0.0039		
	σ [-]	3	3	3	3	3		
Shock Operational – End-Use Handling	One drop on each of six faces shock machine test with half-sine waveform, duration 3ms, minimum velocity change 424 cm/s ±5%, minimum acceleration 50g,						IEC 60068-2-27	
Shock Non-Operational	One drop of each of six faces, shock machine test with trapezoidal waveform, duration (pulse width) 6ms, velocity change of 791 mm/s ±10%, minimum acceleration 30g							

REVISION:	ECR/ECN INFORMATION:	TITLE:	SHEET No.
B	EC No: IPG2016-0349 DATE: 14.04.2016	PRODUCT SPECIFICATION GIGABIT MAGNETIC JACK LED 2x6, 2x4	16 of 23
DOCUMENT NUMBER:		CREATED / REVISED BY:	CHECKED BY:
PS-85728-001		J. Bader / T. Greulich / P. Butschbach	S. Steinke
		APPROVED BY:	

(MECHANICAL AND ENVIRONMENTAL REQUIREMENTS CONTINUED)

PARAMETER	TEST CONDITION	SPECIFICATION REFERENCE	REQUIREMENT
Contact Resistance (Low Level)	Mate connectors: apply a maximum voltage of 20 mV and a current of 100 mA over jack contacts	EIA 364-23B	20 milliohms MAXIMUM [initial] – Bulk resistance removed
Connector Insertion and Removal Force	Mate and unmate connector (male to female) at a rate of 25 ± 6 mm (1 ± ¼ inch) per minute.	EIA 364-13	MAX. insertion force MAX. removal force 20 N (4.5 lbf)
Mating Cycles (Durability)	Mate connectors up to 750 cycles at a maximum rate of 10 cycles per minute prior to Environmental Tests.	IEC 60512-9-1 Test 9a	Contact Resistance: <20 milliohm increase from initial
Effectiveness of Connector Coupling	Rate of load application 44,5 N/s max.	<i>IEC60512-15-6- Test 15f</i>	50 N for 60 s ± 5s.

REVISION:	ECR/ECN INFORMATION:	TITLE:	SHEET No.
B	EC No: IPG2016-0349 DATE: 14.04.2016	PRODUCT SPECIFICATION GIGABIT MAGNETIC JACK LED 2x6, 2x4	17 of 23
DOCUMENT NUMBER:	CREATED / REVISED BY:	CHECKED BY:	APPROVED BY:
PS-85728-001	J. Bader / T. Greulich / P. Butschbach	S. Steinke	

Appendix B: ENVIRONMENTAL REQUIREMENTS

PARAMETER	TEST CONDITION	SPECIFICATION REFERENCE	REQUIREMENT								
Solderability	260 ±5 °C, 3-5s , non active flux, leadfree Solder: Sn Ag 0.55 Cu 0.66	EIA 364-52	Wetting > 90%								
Solder Heat Resistance	Dip connector terminal tails in solder: Solder Duration: 10 ± 0.5 seconds; Solder Temperature: 260 ± 5°C	EIA 364-52	Visual: No damage to insulator material								
Electrical Load and Aging	500 hours at 70° ± 2°C / 350mA (at each pair)										
Dry Heat Climatic cycle	Mate connectors: Temperature: 75°C / Duration: 16 hours	EIA 364-17A									
Damp Heat (Cyclic)	Mate connectors; expose for 2 cycles at 90 - 95% relative humidity with a-transition time of 24 hours one cycle. +25°C/+55°C Note: Remove surface moisture and air dry for 1 hour prior to measurements.	EIA 364-31B	Contact Resistance: <20 milliohms INCREASE FROM INITIAL								
Cold Resistance	Mate connectors: Duration: 2 hours; Temperature: -40 ± 3°C		HiPot: No breakdown at 2250 VDC (Cable-side to PHY-side)								
Corrosion, Industrial Atmosphere: Flowing Mixed Gas (FMG)	Halfmate and unmate connectors: 0.5 ppm SO₂ and 0.1 ppm H₂S Temperature: (25±2)°C Relative humidity (75±3)% Duration: 10 days	IEC 60512-11-7 Test 11g	Signal-transmission: No failure								
Rapid Change of Temperature	Mate connectors; expose to 25 cycles of: <table border="0"> <tr> <td><u>Temperature °C</u></td> <td><u>Duration</u></td> </tr> <tr> <td><u>(Minutes)</u></td> <td></td> </tr> <tr> <td>-40</td> <td>30</td> </tr> <tr> <td>+70</td> <td>30</td> </tr> </table> Recovery time: 2 hours	<u>Temperature °C</u>	<u>Duration</u>	<u>(Minutes)</u>		-40	30	+70	30		Visual: No damage
<u>Temperature °C</u>	<u>Duration</u>										
<u>(Minutes)</u>											
-40	30										
+70	30										
Damp Heat Steady State (Humidity)	Humidity: 93% Temperature: 40°C Duration: 21days										

REVISION:	ECR/ECN INFORMATION:	TITLE:	SHEET No.
B	EC No: IPG2016-0349 DATE: 14.04.2016	PRODUCT SPECIFICATION GIGABIT MAGNETIC JACK LED 2x6, 2x4	18 of 23
DOCUMENT NUMBER:	CREATED / REVISED BY:	CHECKED BY:	APPROVED BY:
PS-85728-001	J. Bader / T. Greulich / P. Butschbach	S. Steinke	

Appendix C: STANDARDS AND NORMATIVE REFERENCES

Standard	Test	Description
IEC 60068-2-6	Fc	Environmental testing - Part 2-6: Tests - Test Fc: Vibration (sinusoidal)
IEC 60068-2-14	Na	Environmental testing – Part 2-14: Tests – Test N: Change of Temperature
IEC 60068-2-20	T	Environmental testing – Part 2-2-: Tests – Test T: Test methods for solderability and resistance to soldering heat of devices with leads
IEC 60068-2-27	Ea	Environmental testing - Part 2-27: Tests - Test Ea and guidance: Shock
IEC 60068-2-38	Z/AD	Environmental testing – Part 2-38: Tests – Test Z/AD: Composite temperature/humidity cyclic test
IEC 60068-2-58	Td	Environmental testing - Part 2-58: Tests - Test Td: Test methods for solderability, resistance to dissolution of metallization and to soldering heat of surface mounting devices (SMD)
IEC 60068-2-64	Fh	Environmental testing - Part 2-64: Tests - Test Fh: Vibration, broadband random and guidance
IEC 60512-1-1	1a	Part 1-1: General examination – Test 1a: Visual examination
IEC 60512-2-1	2a	Part 2-1: Electrical continuity and contact resistance tests; Test 2a: Contact resistance - Millivolt level method
IEC 60512-9-1	9a	Part 9-1: Endurance tests - Test 9a: Mechanical operation
IEC 60512-9-2	9b	Connectors for electronic equipment - Tests and measurements - Part 9-2: Endurance tests - Test 9b: Electrical load and temperature
IEC 60512-11-7	11g	Connectors for electronic equipment - Tests and measurements - Part 11-7: Climatic tests - Test 11g: Flowing mixed gas corrosion test
IEC 60512-13-2	13b	Part 13-2: Mechanical operation tests - Test 13b: Insertion and withdrawal force
IEC 60512-15-6	15f	Connectors for electronic equipment – Tests and measurements Part 15 - : Connector tests (mechanical) – Test 15f: Effectiveness of connector coupling devices
IEC 60603-7		Connectors for electronic equipment - Part 7: Detail specification for 8-way, unshielded, free and fixed connectors
IEC 60603-7-1		Connectors for electronic equipment - Part 7-1: Detail specification for 8-way, shielded, free and fixed connectors
IEC 60603-7-5		Connectors for electronic equipment - Part 7-5: Detail specification for 8-way, shielded, free and fixed connectors, for data transmissions with frequencies up to 250 MHz

B	REVISION:	ECR/ECN INFORMATION:	TITLE:	PRODUCT SPECIFICATION GIGABIT MAGNETIC JACK LED 2x6, 2x4	SHEET No.
		EC No: IPG2016-0349			19 of 23
		DATE: 14.04.2016			
DOCUMENT NUMBER:			CREATED / REVISED BY:	CHECKED BY:	APPROVED BY:
PS-85728-001			J. Bader / T. Greulich / P. Butschbach	S. Steinke	

(STANDARDS AND NORMATIVE REFERENCES CONTINUED)

Standard	Test	Description
IEC 62471		Photobiological safety of lamps and lamp systems
IEC 60950-1		Information technology equipment – Safety – Part 1: General Requirements
IEEE 802.3		Standard for Ethernet
TIA-1096-A		Telecommunications – Telephone Terminal Equipment – Connector Requirements for Connection of Terminal Equipment to the Telephone Network

Appendix D: TEST REQUIREMENT ADDITIONAL TO POETEC

PARAMETER	TEST CONDITION	SPECIFICATION REFERENCE	REQUIREMENT
Visual Inspection	Test 1a	IEC 60512-1-1	No defects that would impair normal operation
Gauging Continuity	All signal contact and screen specimens Annex A	IEC 60603-7-5	Contact disturbance 10µs Maximum

REVISION: B	ECR/ECN INFORMATION: EC No: IPG2016-0349 DATE: 14.04.2016	TITLE: PRODUCT SPECIFICATION GIGABIT MAGNETIC JACK LED 2x6, 2x4	SHEET No. 20 of 23
DOCUMENT NUMBER: PS-85728-001		CREATED / REVISED BY: J. Bader / T. Greulich / P. Butschbach	CHECKED BY: S. Steinke
		APPROVED BY:	

Appendix E: TEST SEQUENCE

ITEM	DESCRIPTION	GROUP P	GROUP AP	GROUP BP	GROUP CP	GROUP DP	GROUP EP	GROUP FP
1	Visual Inspection	1	6,11	8	3	4		5
2	Contact Resistance	2	4,8	4,6	2	2,		2,4
3	HiPot	3	5,15	7		3		
4	Insertion and Removal Force		1,9					
5	Effectiveness of Connector Coupling		2,10					
6	Durability (half rated cycles)			2,5				
7	Vibration				1			
8	Gauging Continuity					5		
9	Solderability		12					
10	Solder Heat Resistance		13					
11	Rapid Change of Temperature		3					
12	Climatic Cycle		7					3
13	Flowing Mixed Gas Corrosion			3				
14	Electrical Load and Aging					1		
15	Damp Heat Steady State (Humidity)							1
16	Insertion Loss						1	
17	Return Loss						2	
18	NEXT						3	
19	CMR						4	
20	OCL						5	
	Sample Quantity		8	8	8	8	8	8

Notes:

Group P to be completed on all samples before testing begins excluding Group EP

Where contact resistance measurements are not possible, Insertion Loss should be completed instead

REVISION: B	ECR/ECN INFORMATION: EC No: IPG2016-0349 DATE: 14.04.2016	TITLE: PRODUCT SPECIFICATION GIGABIT MAGNETIC JACK LED 2x6, 2x4	SHEET No. 21 of 23
DOCUMENT NUMBER: PS-85728-001	CREATED / REVISED BY: J. Bader / T. Greulich / P. Butschbach	CHECKED BY: S. Steinke	APPROVED BY:

Appendix F: : ROHS COMPLIANCE / SAFETY APPROVAL

All versions of the Gigabit Magnetic Jack are RoHS compliant and lead free.

UL Certification to UL/IEC 60950 pending: File E177474

Appendix G: HANDLING AND STORAGE

F.1 Soldering and Washing Process

For details please refer to application specification AS-85719-001

F.2 Storage

- The modules have to be stored under the conditions shown on the table below:

Parameter	Min	Max	Units
Storage temperature	5	50	°C
Storage humidity	20	70	% RH

- Avoid areas with corrosive agents (gases) or dust.
- Do not store the modules in direct sunlight or humid environment.
- Avoid freezing and condensation.
- It is recommended to use the modules within 6 months after delivery.
- Solderability guaranteed for 6 months after delivery.
- Do not open the original package until immediately before use.

For further information please contact Molex

REVISION: B	ECR/ECN INFORMATION: EC No: IPG2016-0349 DATE: 14.04.2016	TITLE: PRODUCT SPECIFICATION GIGABIT MAGNETIC JACK LED 2x6, 2x4	SHEET No. 22 of 23
DOCUMENT NUMBER: PS-85728-001	CREATED / REVISED BY: J. Bader / T. Greulich / P. Butschbach	CHECKED BY: S. Steinke	APPROVED BY:



PRODUCT SPECIFICATION

Released Revision Control

Revision	Change	Person Responsible	ECN No	Date
A	First issued	NA	NA	
B	Update on supported versions	P. Butschbach	IPG2016-0349	14.04.2016

REVISION: B	ECR/ECN INFORMATION: EC No: IPG2016-0349 DATE: 14.04.2016	TITLE: PRODUCT SPECIFICATION GIGABIT MAGNETIC JACK LED 2x6, 2x4	SHEET No. 23 of 23
DOCUMENT NUMBER: PS-85728-001	CREATED / REVISED BY: J. Bader / T. Greulich / P. Butschbach	CHECKED BY: S. Steinke	APPROVED BY: