

LOC	DIST	REVISIONS					
GP	00	P	LTN	DESCRIPTION	DATE	DWN	APVD
		A		RELEASED PER ECO-12-013192	08OCT2012	BMM	MRS
		A1		RELEASED PER ECO-14-008488	06JUNE2014	PP	SH

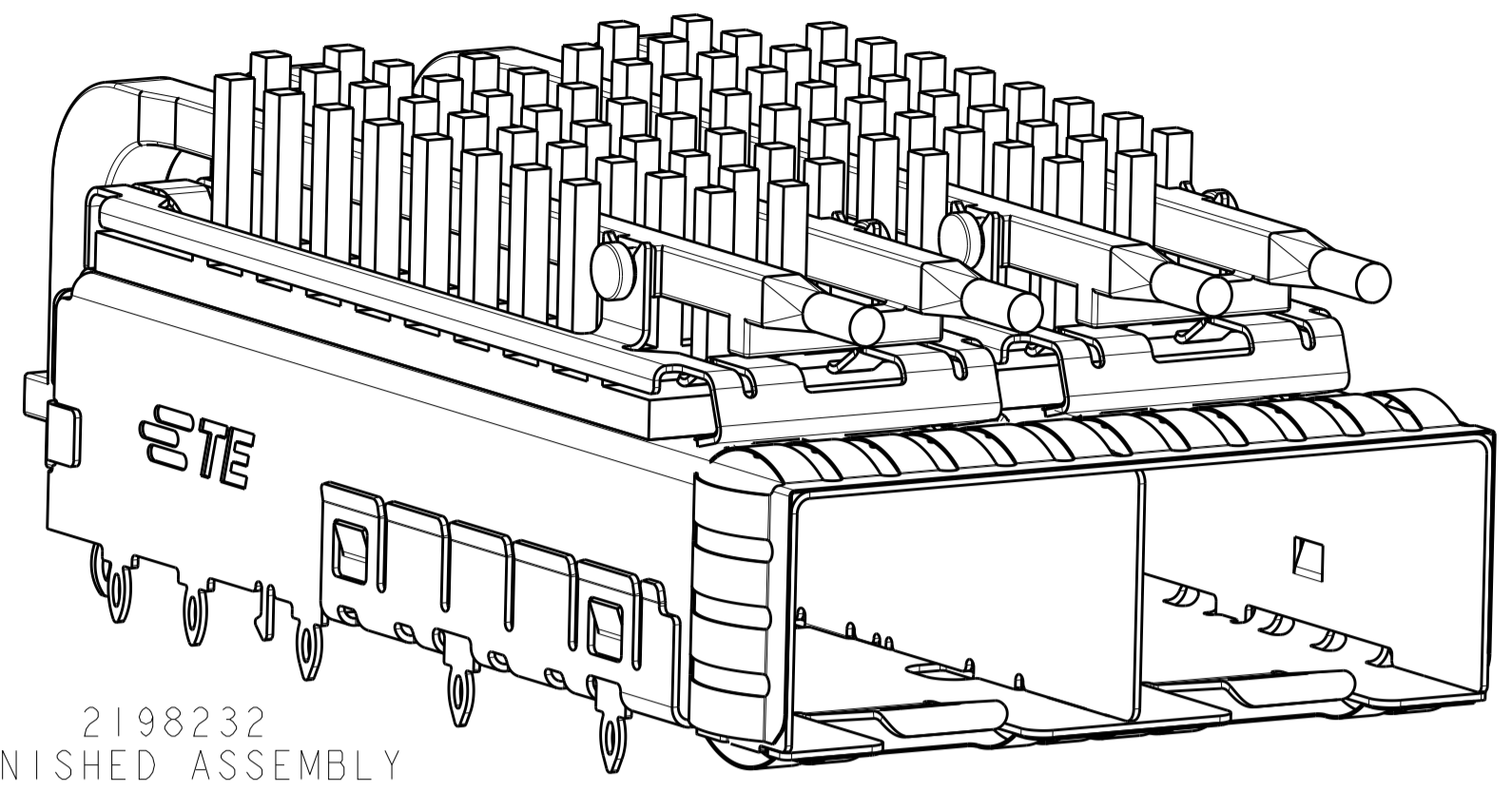

2198232
FINISHED ASSEMBLY
SCALE 4:1

- 1 MATERIAL:
CAGE ASSEMBLY: 0.25mm THICK NICKEL SILVER ALLOY
EMI SPRINGS: COPPER ALLOY
HEAT SINK: ALUMINUM
HEAT SINK/LIGHTPIPE CLIP: STAINLESS STEEL.
LIGHTPIPE: POLYCARBONATE, CLEAR
- 2 FINISH:
SPRINGS: MINIMUM OF 0.8um TIN PLATE OVER MINIMUM OF 0.8um NICKEL UNDERPLATE. NON-PLATED EDGES PERMISSIBLE.
HEAT SINK: ELECTROLESS NICKEL
HEAT SINK CLIP: PASSIVATE.
- 3 DATUM AND BASIC DIMENSIONS ESTABLISHED BY CUSTOMER.
- 4 PADS AND VIAS CHASSIS GROUND.
- 5 MATES WITH SFP MSA COMPLIANT RECEIVERS.
- 6 INTERPRETATION OF DATUM REFERENCE FRAME IN ACCORDANCE WITH SECT 4.4.1.1 OR ASME Y14.5M-1994.
- 7 MINIMUM PC BOARD THICKNESS:
SINGLE SIDED: 1.5mm
DOUBLE SIDED: 2.25mm
- 8 HOLE PATTERN REPEATS FOR EACH PORT, SPACING BETWEEN PORTS IS 14.25mm.
- 9 REFERENCE APPLICATION SPEC. 114-13120, HOLE A, FOR RECOMMENDED DRILL HOLE DIAMETER AND PLATING THICKNESS.

- 10 REFERENCE APPLICATION SPEC. 114-13120, HOLE B, FOR RECOMMENDED DRILL HOLE DIAMETER AND PLATING THICKNESS.
- 11 CERTAIN MATING TRANCEIVERS MAY REQUIRE ADDITIONAL PCB THICKNESS THAT WOULD NEED TO BE DETERMINED BY THE CUSTOMER.
- 12 PRODUCT COMPLIES WITH SPECIFICATION SFF-8433 IMPROVED PLUGGABLE FORM FACTOR FOR SFP+ GANGED CAGES.
- 13 DIMENSION APPLIES PRIOR TO INSERTION OF SFP MODULE.
- 14 HEATSINK, HEATSINK CLIP, AND LIGHTPIPE SHIPPED UNASSEMBLED TO CAGE ASSEMBLY. CAGE ASSEMBLY TO BE PRESSED INTO PCB PRIOR TO ATTACHING HEATSINK, HEATSINK CLIP, AND LIGHTPIPE TO THE CAGE ASSEMBLY.
- 15 PACKAGED AS A COMPLETE ASSEMBLY.

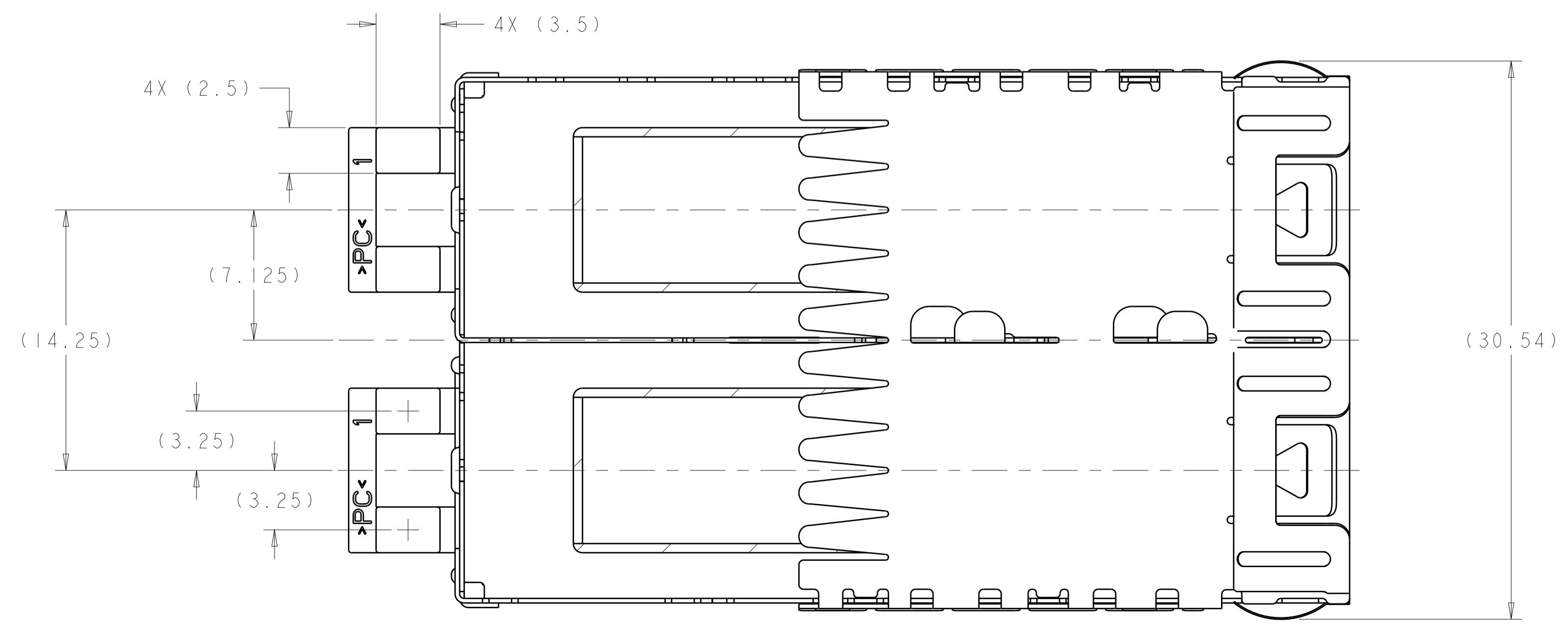
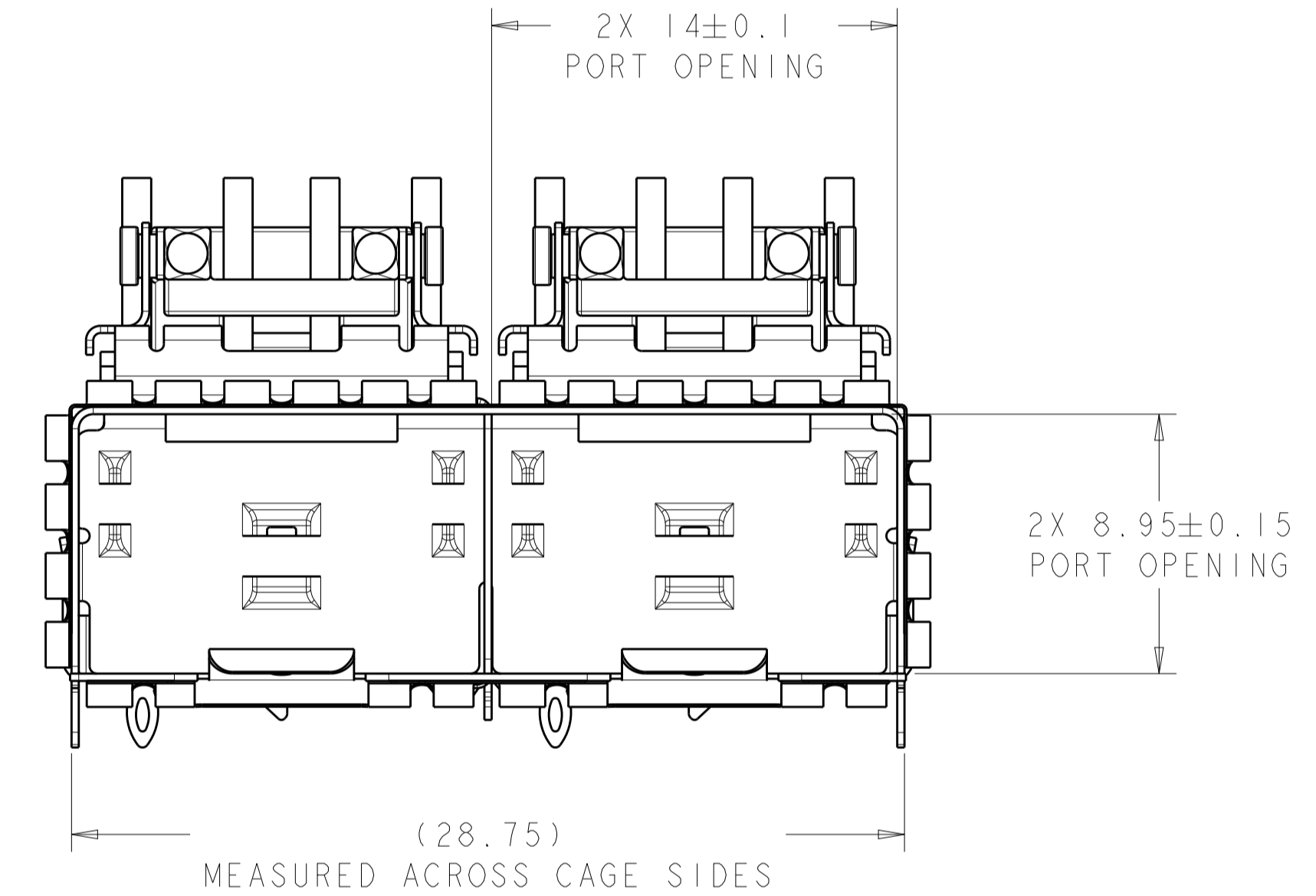
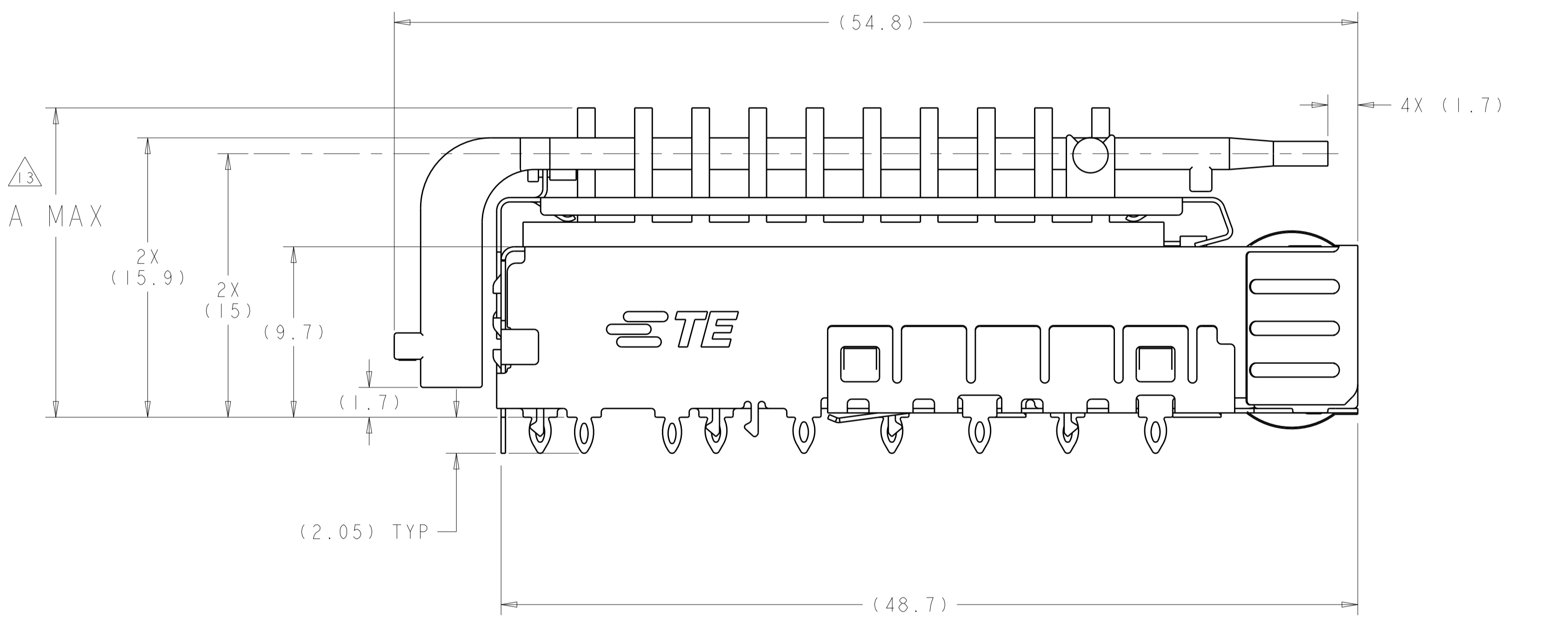

13	22.5	NETWORKING, TALL	2198232-4
13	18.1	NETWORKING, SHORT	2198232-3
14	15.5	SAN	2198232-2
14	13.2	PCI	2198232-1
	A MAX	DESCRIPTION	PART NUMBER

THIS DRAWING IS A CONTROLLED DOCUMENT.

DIMENSIONS: mm

TOLERANCES UNLESS OTHERWISE SPECIFIED:

0 PLC	±0.13
1 PLC	±0.1
2 PLC	±0.08
3 PLC	±0.05
4 PLC	±0.05
ANGLES	±0.1

MATERIAL:

FINISH:

Customer Drawing

OWN: B. MATTHEWS 01NOV2011
CHK: M. SCHMITT 01NOV2011
APVD: M. SCHMITT 01NOV2011

PRODUCT SPEC: 108-2364
APPLICATION SPEC: 114-13120
WEIGHT: -

NAME: SFP+ ENHANCED 1X2 CAGE ASSEMBLY, PRESS-FIT, EXTERNAL EMI SPRINGS WITH HEATSINK AND LIGHTPIPE

SIZE: A1
CAGE CODE: 00779
DRAWING NO: 2198232

RESTRICTED TO: -

SCALE: 5:1 SHEET: 1 OF 4 REV: A1

LOC	DIST	REV	DATE	BY	APPV
GP	00				

REVISIONS		DATE	BY	APPV
1	SEE SHEET 1	-	-	-

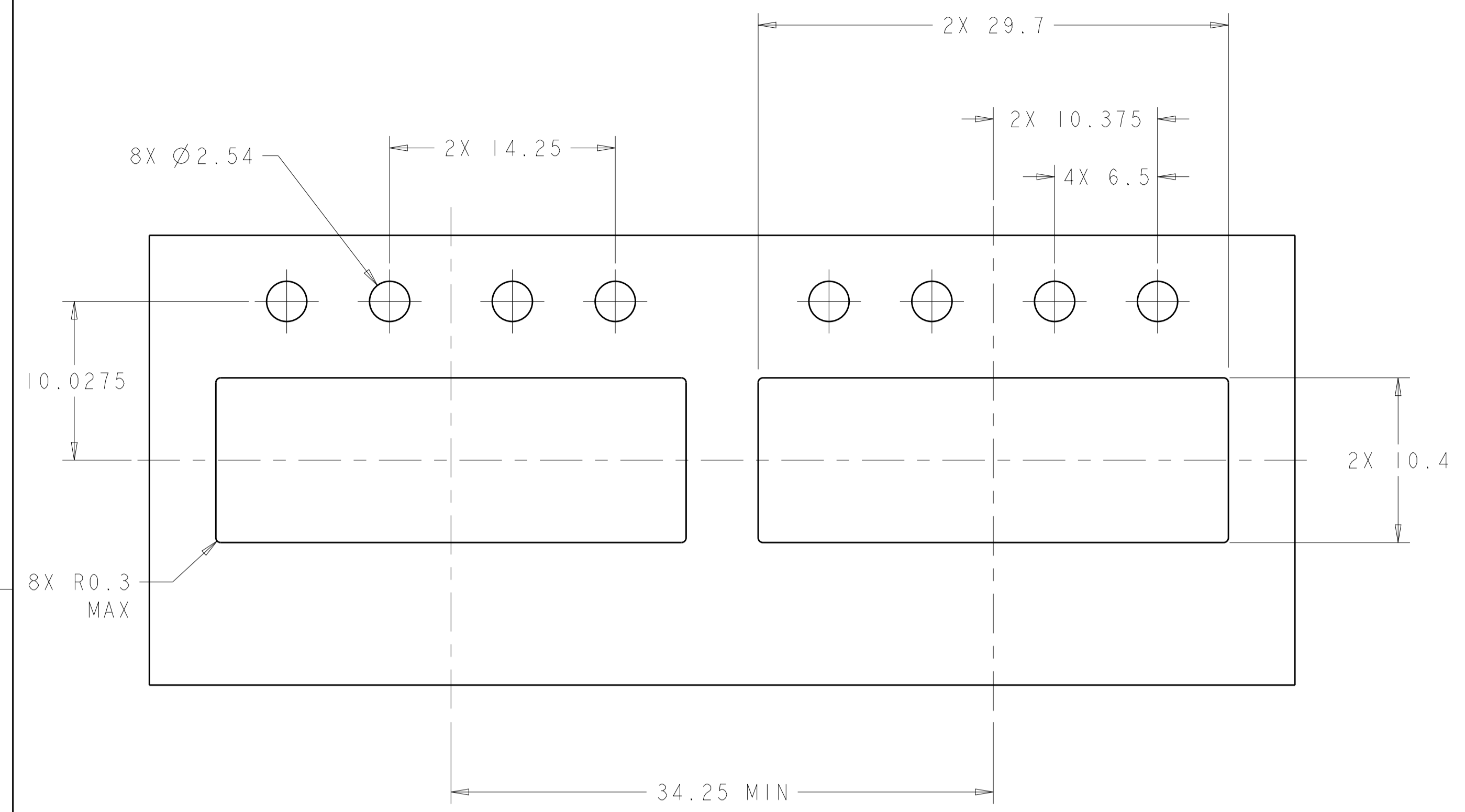

RECOMMENDED BEZEL CUT-OUT
 SINGLE SIDED APPLICATIONS
 SCALE 4:1

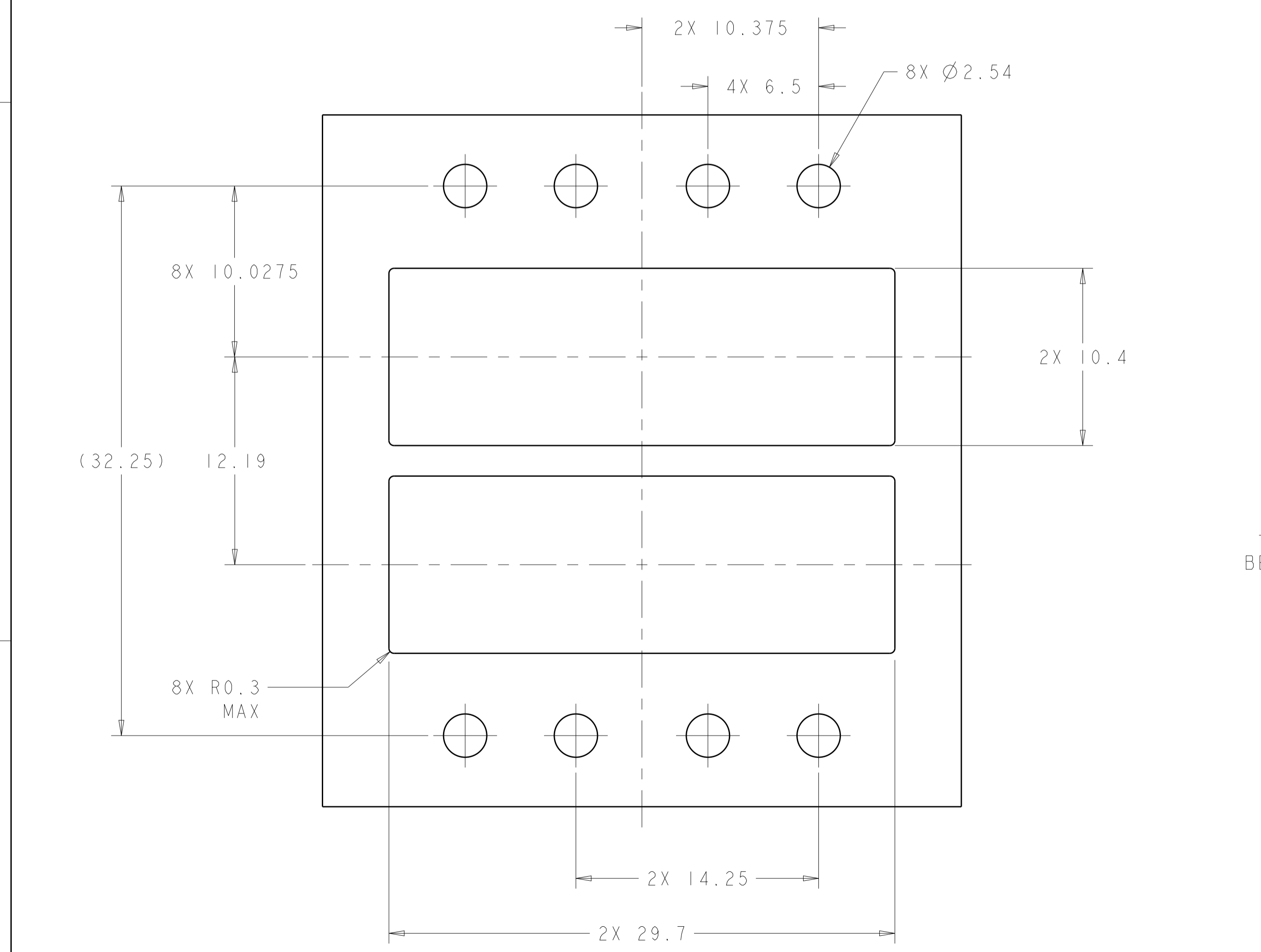

RECOMMENDED BEZEL CUT-OUT
 BELLY TO BELLY APPLICATIONS

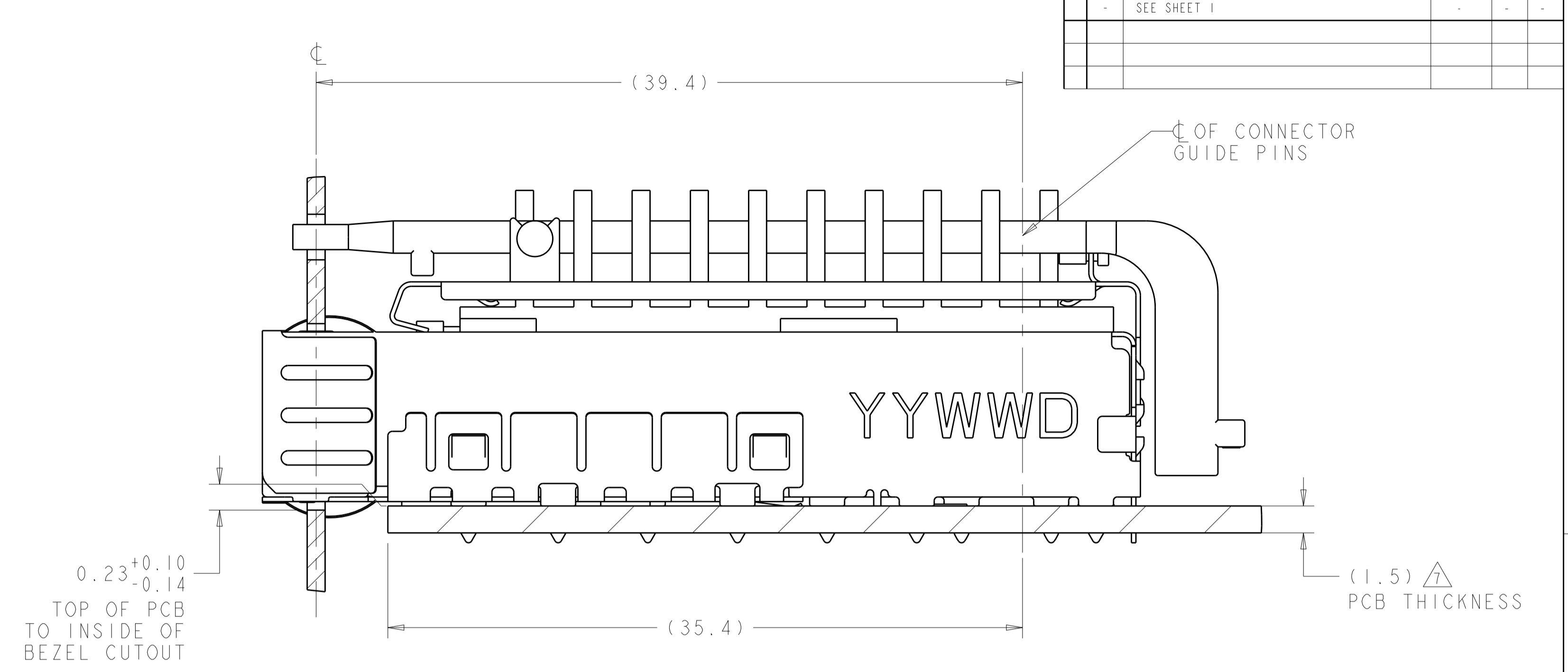

2198232
 MOUNTED ON PC BOARD
 SHOWN THRU RECOMMENDED BEZEL

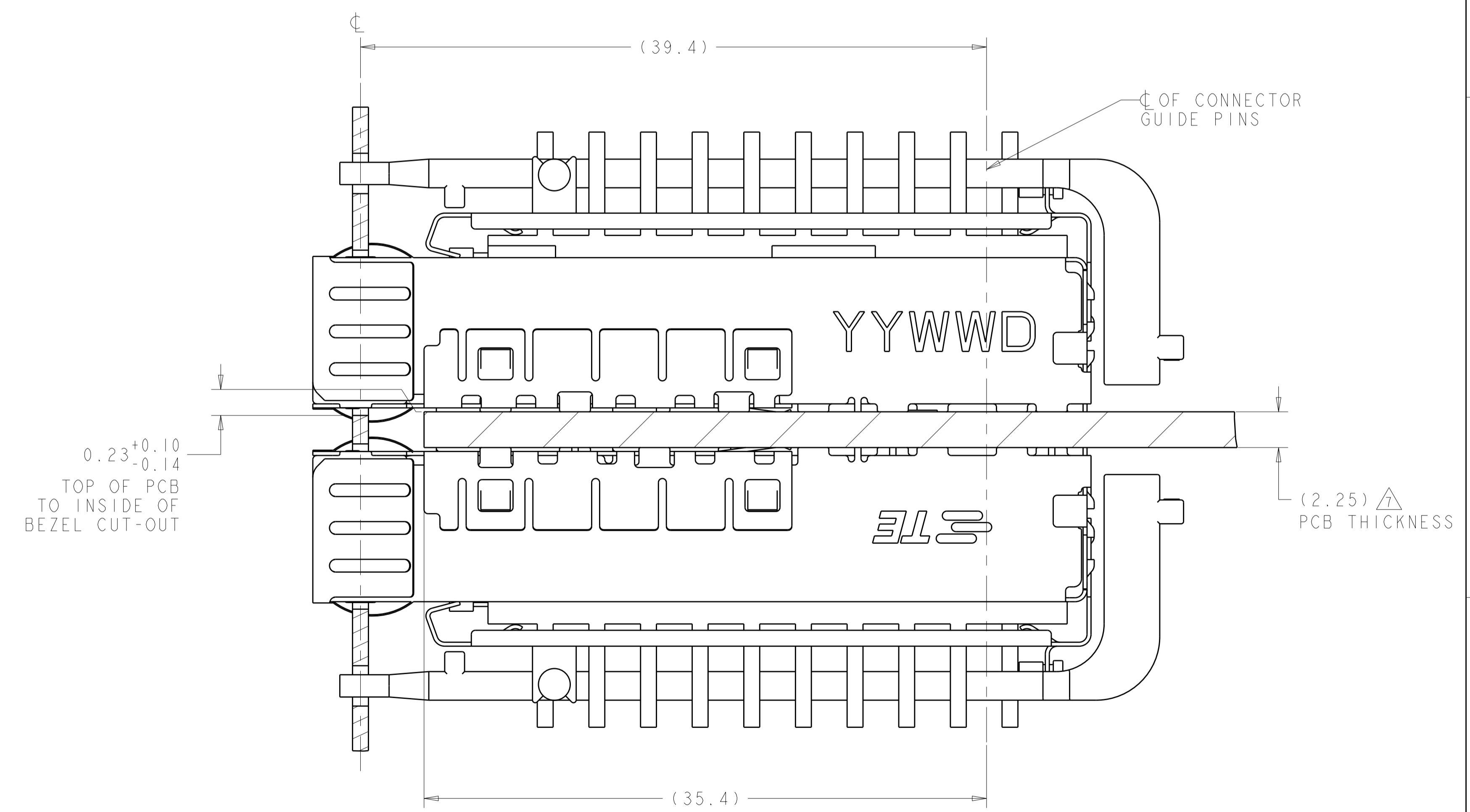

2198232
 MOUNTED BELLY TO BELLY ON PC BOARD
 SHOWN THRU RECOMMENDED BEZEL

THIS DRAWING IS A CONTROLLED DOCUMENT.		OWN: B. MATTHEWS 01NOV2011	TE Connectivity
DIMENSIONS: mm		CHK: M. SCHMITT 01NOV2011	
TOLERANCES UNLESS OTHERWISE SPECIFIED:		APVD: M. SCHMITT 01NOV2011	NAME: SFP+ ENHANCED 1X2 CAGE ASSEMBLY, PRESS-FIT, EXTERNAL EMI SPRINGS WITH HEATSINK AND LIGHTPIPE PRODUCT SPEC: 108-2364 APPLICATION SPEC: 114-13120
0 PLC ±0.13 1 PLC ±0.1 2 PLC ±0.08 3 PLC ±0.05 4 PLC ±0.05 ANGLES ±0.5		SIZE: CAGE CODE DRAWING NO: A100779 WEIGHT: - Customer Drawing	
MATERIAL: FINISH: -		RESTRICTED TO: -	SCALE: 5:1 SHEET: 2 OF 4 REV: A1

LOC	DIST	REV	DATE	APP'D
GP	00			

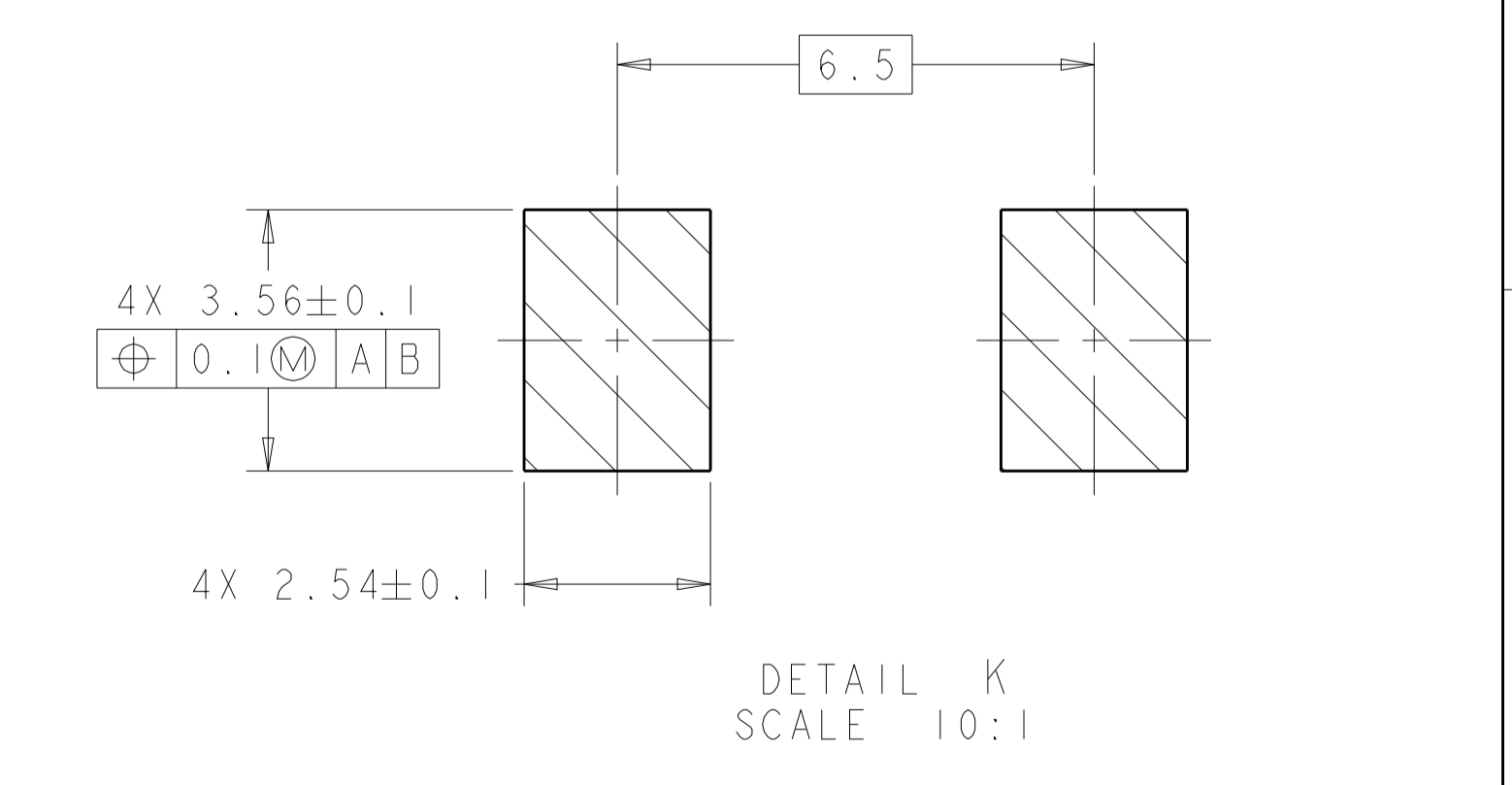
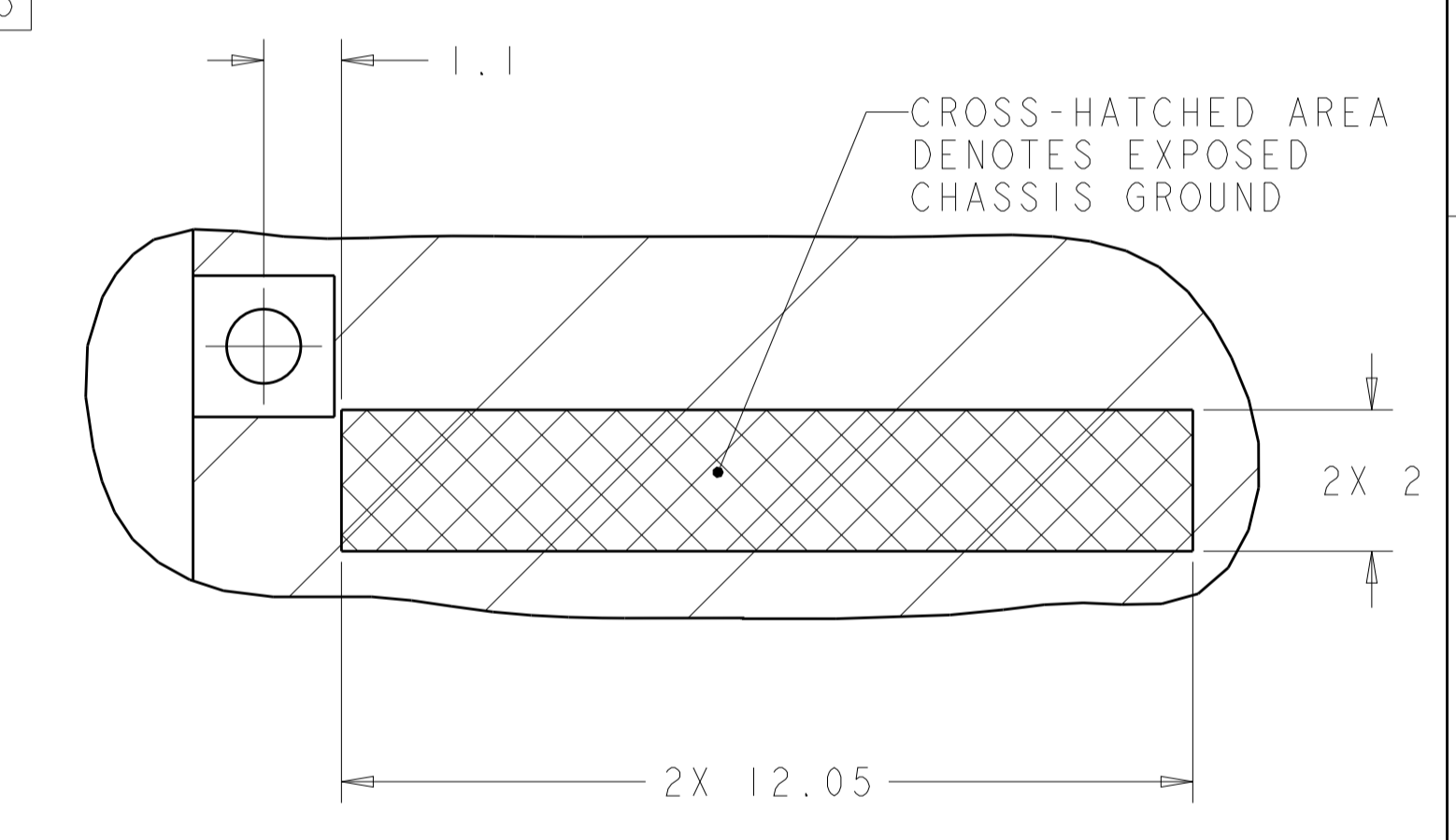
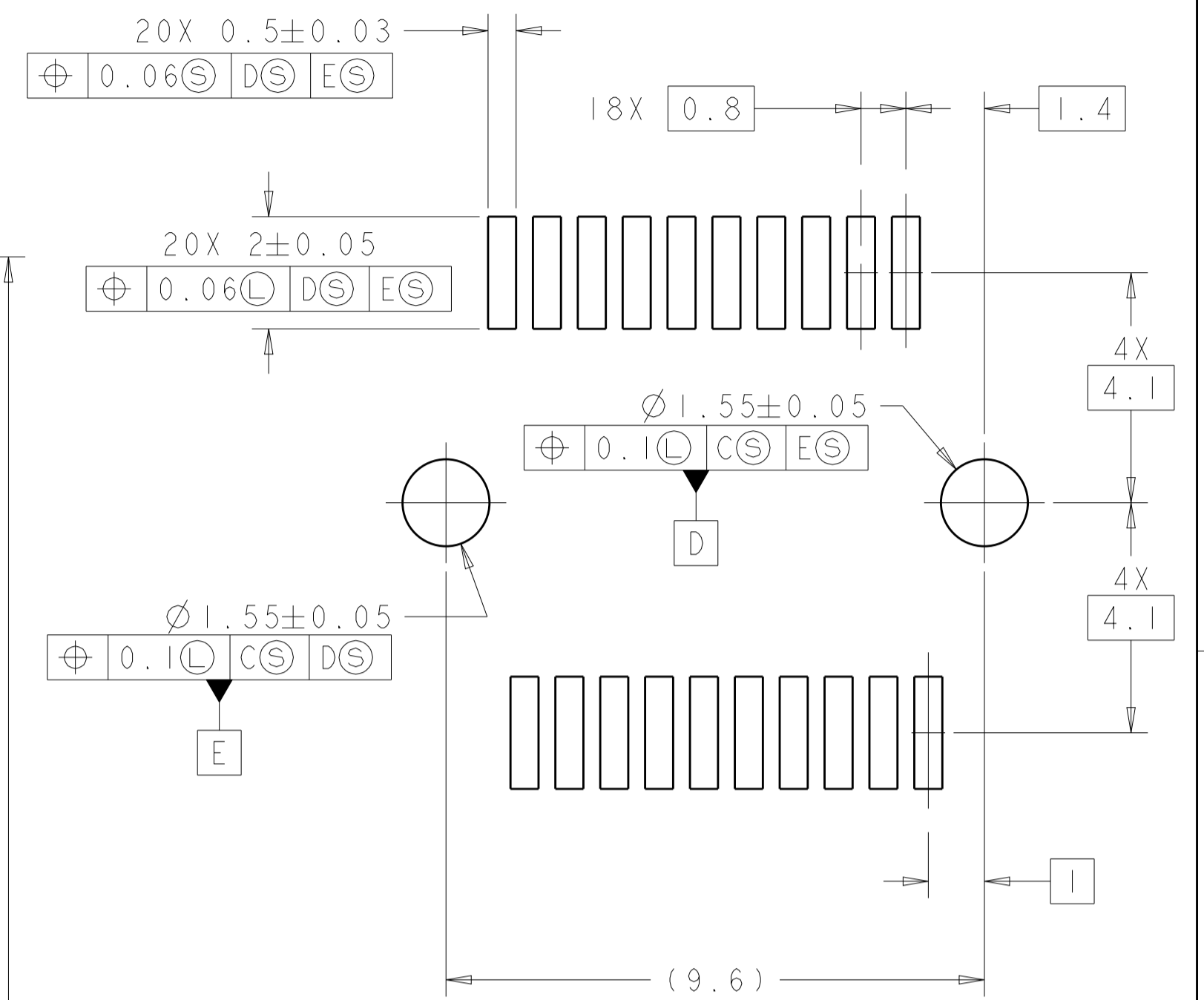
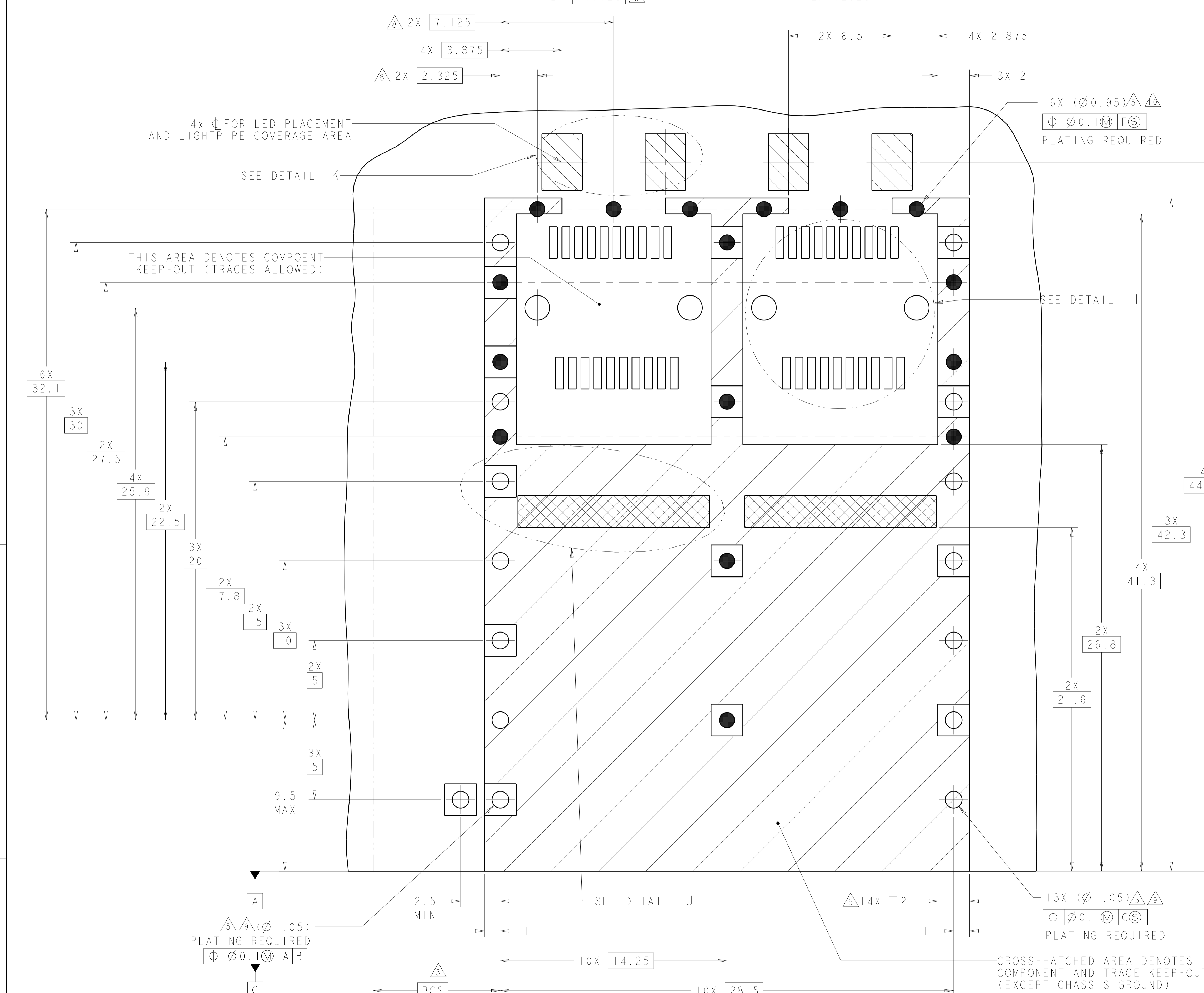

THIS DRAWING IS A CONTROLLED DOCUMENT.		OWN: B. MATTHEWS 01NOV2011	TE Connectivity
DIMENSIONS: mm		CHK: M. SCHMITT 01NOV2011	
TOLERANCES UNLESS OTHERWISE SPECIFIED:		APVD: M. SCHMITT 01NOV2011	NAME: SFP+ ENHANCED 1X2 CAGE ASSEMBLY, PRESS-FIT, EXTERNAL EMI SPRINGS WITH HEATSINK AND LIGHTPIPE PRODUCT SPEC: 108-2364 APPLICATION SPEC: 114-13120
0 PLC ± 0.13 1 PLC ± 0.1 2 PLC ± 0.08 3 PLC ± 0.05 4 PLC ± 0.05 ANGLES ± 0.5		SIZE: 114-13120 WEIGHT: - Customer Drawing	
MATERIAL: FINISH: Δ		SCALE: 5:1	RESTRICTED TO: -
		SHEET: 4 OF 4	REV: A1