

4

3

2

1

THIS DRAWING IS UNPUBLISHED.

RELEASED FOR PUBLICATION

,1997 .

© COPYRIGHT 1997

BY AMP INCORPORATED. ALL RIGHTS RESERVED.

LOC DS

DIST

REVISIONS

P	LTR	DESCRIPTION	DATE	DWN	APVD
	O	RELEASED ECN(RD97-056)	11,MAR,'97	JW	JK
	A	REVISED ECN(RD97-067)	25,MAR,'97	JW	JK
	B	REVISED ECN(FC00-0069-01)	23,JUN,'01	JW	CS
	C	REVISED ECN(FC00-0124-01)	12,NOV,'01	JW	CS

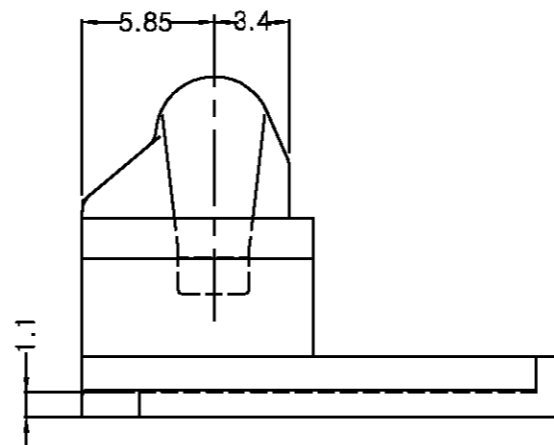
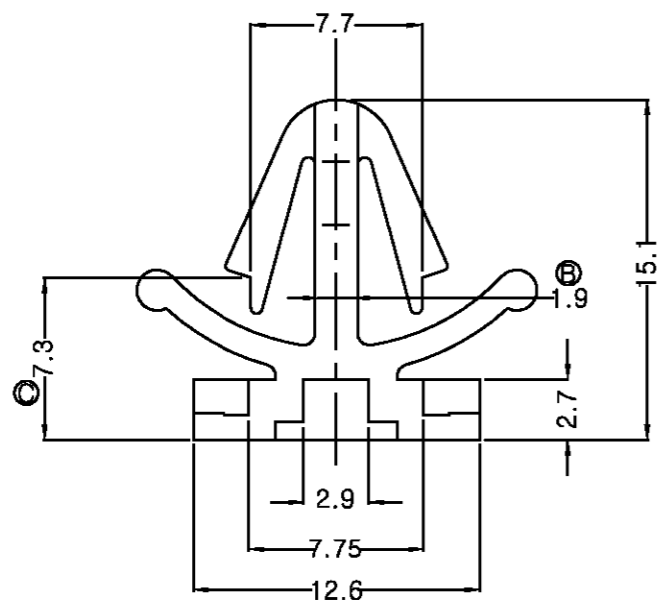
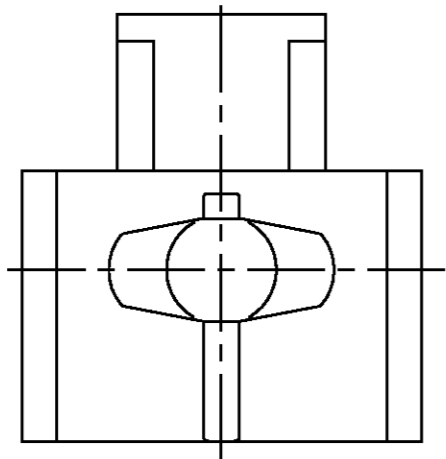

PANEL HOLE SIZE

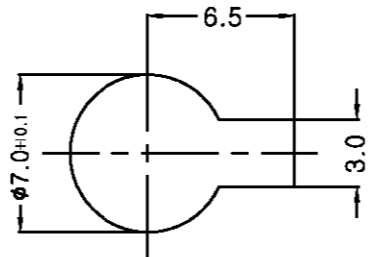

PANEL THICKNESS : 0.7-1.6mm

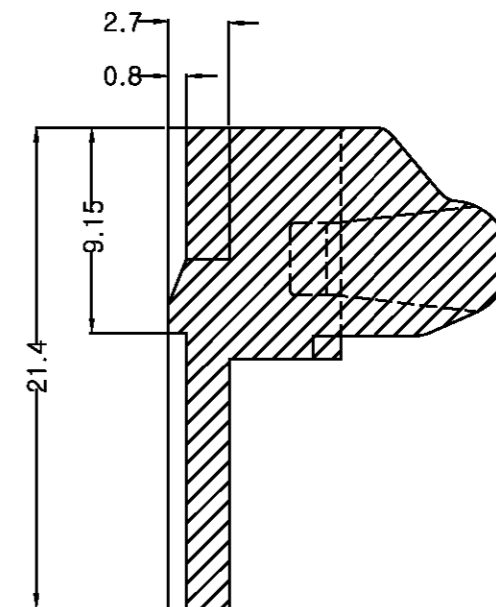

SECTION A-A

NOTE.

1 MATERIAL : NYLON66
2 COLOR

1 NATURAL	368165-2
2 BLACK	368165-1
COLOR	PART NO.

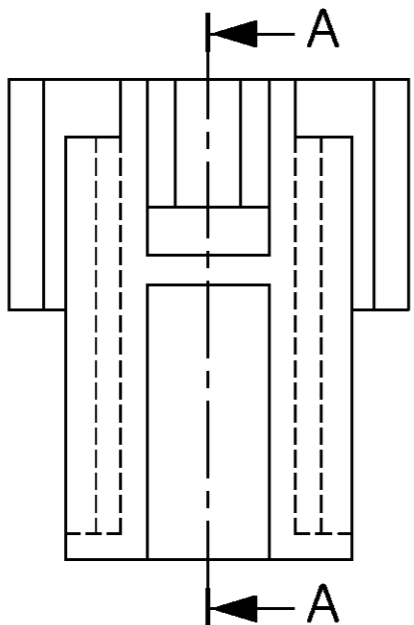

THIS DRAWING IS CONTROLLED DOCUMENT FOR AMP INCORPORATED. IT IS SUBJECT TO CHANGE AND THE CONTROLLING ENGINEERING ORGANIZATION SHOULD BE CONTACTED FOR THE LATEST REVISION.		DWN JW JUNG	AMP AMP KOREA. kyungsan, korea		
DIMENSIONS: MM		CHK BM JANG			
TOLERANCES UNLESS OTHERWISE SPECIFIED: 0 <XXX<10 ± 0.2 10<XXX<30 ± 0.25 30<XXX ± 0.3 ANGLES ± 3°		APVD CS LEE	NAME CLIP HSG FOR 070 & EJ (φ7 PANEL)		
3rd ANGLE PROJECTION		PRODUCT SPEC ---	SIZE A3	CAGE CODE 00779	DRAWING NO C= 368165
MATERIAL SEE NOTE		APPLICATION SPEC ---	WEIGHT ---	SCALE 3:1	SHEET 1 OF 1
FINISH SEE TABLE		REV C			