

THIS DRAWING IS UNPUBLISHED. RELEASED FOR PUBLICATION  
 © COPYRIGHT - By - ALL RIGHTS RESERVED.

LOC		DIST		REVISIONS			
P	LTR	DESCRIPTION		DATE	DWN	APVD	
	L1	REVISED PER ECO-11-004587		11MAR11	RK	HMR	

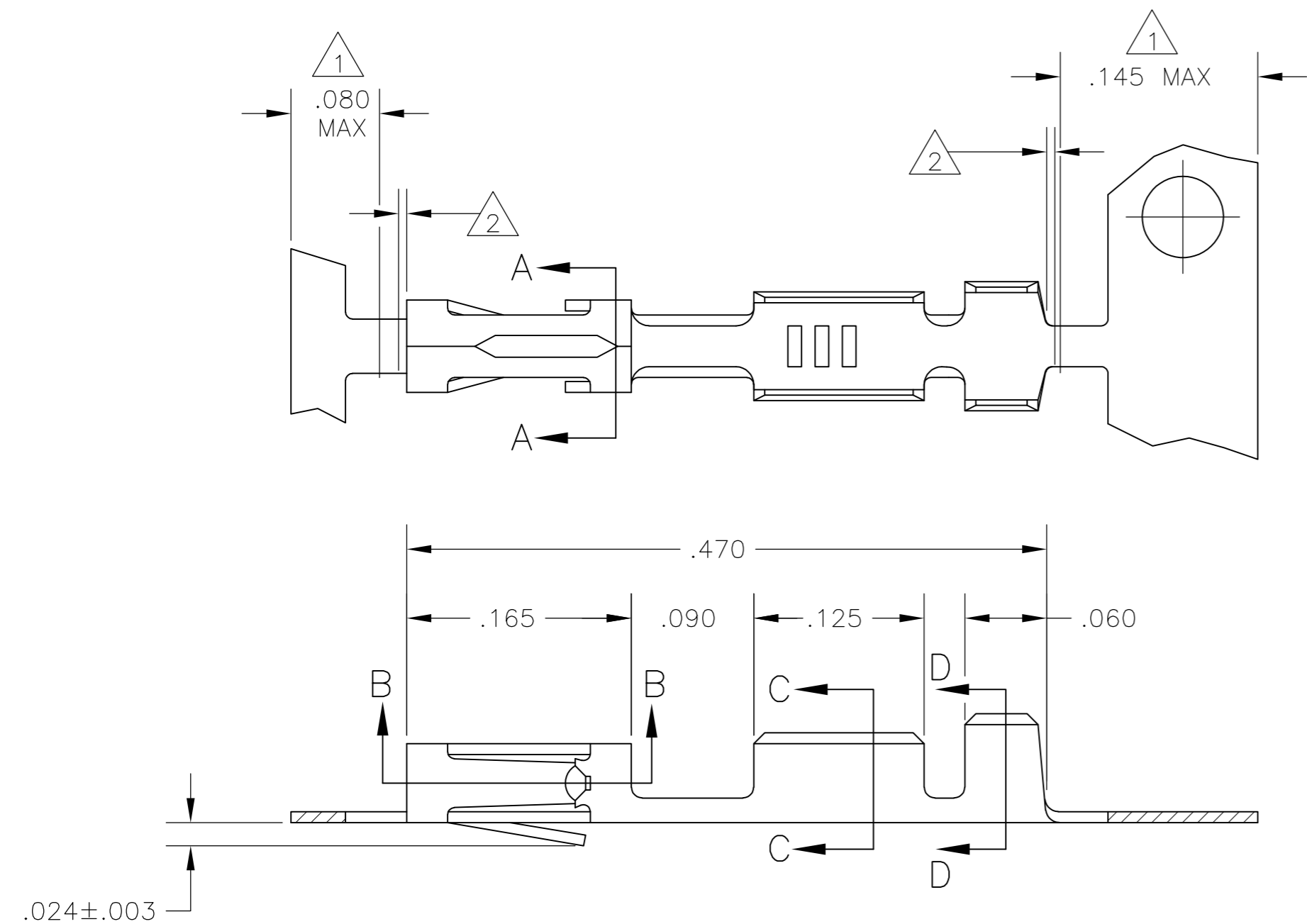

- 1 PLATING IS NOT REQUIRED IN THIS AREA.
- 2 .006 MAX LOOSE PIECE CUT-OFF.
- 3 POINT OF MEASUREMENT FOR PLATING THICKNESS, INSIDE BEAMS
- 4 .000050-.000150 PREPLATED BRIGHT TIN.
- 5 .000030 GOLD IN CONTACT AREA, GOLD FLASH ON THE REMAINDER, ALL OVER .000050 NICKEL.
- 6 .000030 GOLD OVER .000050 NICKEL ENTIRE TERMINAL.
- 7 .000050 GOLD OVER .000050 NICKEL ENTIRE TERMINAL.
- 8 .000015 GOLD IN CONTACT AREA, GOLD FLASH ON THE REMAINDER, ALL OVER .000050 NICKEL.
- 9 SHEAR EDGE ARE PERMITTED TO BE UNPLATED.
- 10 .000015 GOLD IN CONTACT AREA, .000050 NICKEL ON ENTIRE TERMINAL.
- 11 OBSOLETE PART NUMBER.

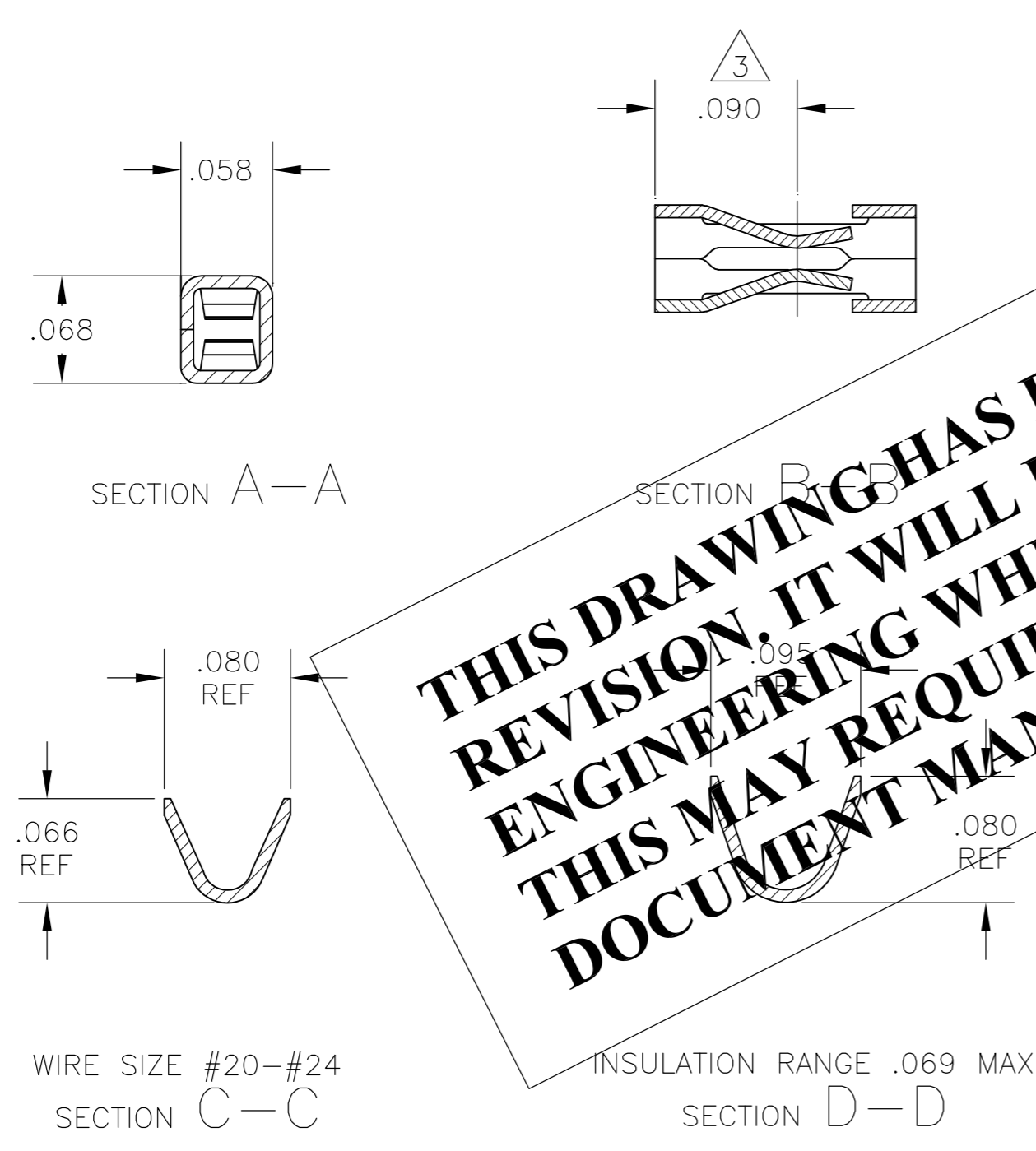

**THIS DRAWING HAS BEEN TRANSLATED AND REFLECTS THE PREVIOUS REVISION. IT WILL REQUIRE A COMPLETE DRAWING CHECK BY PRODUCT ENGINEERING WHEN THE NEXT ECO CHANGE IS WRITTEN - THIS MAY REQUIRE A CHANGE TO THE REVISION OF THE DOCUMENT MANAGER FOLDER AND THIS DRAWING.**

2-87309-5	<del>OBSOLETE</del>	2-87309-4
2- -3	<del>OBSOLETE</del>	2- -1
2- 11 -0	1- 11 -8	1 11 -9
1- 11 -7	11 -6	1 11 -2
1- 11 -6	11 -5	1 11 -1
1- 11 -5	11 -4	1 11 -0
1- -4	-3	-9
1-87309-3	87309-2	87309-8
LOOSE PIECE PART NUMBER	STANDARD APPLICATOR PART NUMBER	MINI APPLICATOR PART NUMBER
	FINISH	

THIS DRAWING IS A CONTROLLED DOCUMENT.		DWN L D RINGLEY 28JAN85	<b>STE</b> TE Connectivity	
DIMENSIONS: INCHES		CHK R J DAVIS 30JAN85		
TOLERANCES UNLESS OTHERWISE SPECIFIED:		APVD R J DAVIS 30JAN85	NAME CONTACT, MOD V CRIMP SNAP-IN	
0 PLC ± -		PRODUCT SPEC -	SIZE A2 CAGE CODE 00779 DRAWING NO C=87309	
1 PLC ± -		APPLICATION SPEC -	RESTRICTED TO -	
2 PLC ± -		WEIGHT -	SCALE 10:1 SHEET 1 of 1 REV L1	
3 PLC ± .005		CUSTOMER DRAWING		
4 PLC ± -				
ANGLES ± -				
FINISH SEE TABLE				
MATERIAL PHOS. BRONZE .008 THICK				

WIRE SIZE #20-#24  
SECTION C-C

INSULATION RANGE .069 MAX  
SECTION D-D