

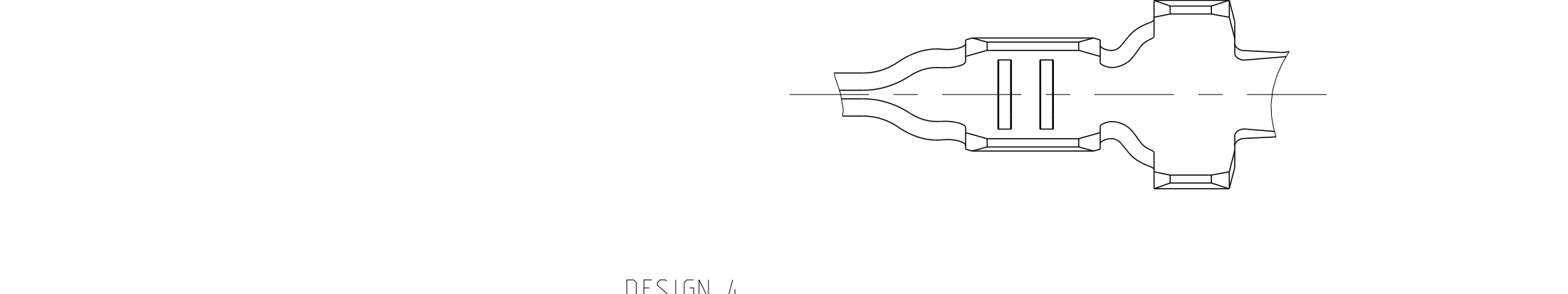

REV.	DESIGN Ausführung	MATERIAL Werkstoff	SURFACE Oberfläche	WIRE RANGE Drahtgrößen Bereich (mm <sup>2</sup> )	INSULATION Isolations Ø (mm)	STRIP FORM WIRE CRIMP Drahtcrimp Bandware	INSUL.-CRIMP Iso-Crimp Bandware	A	B	C	D	E
1	A	CuSn4	PRET INNED vorverzinkt min. 0.8 µm	0.5-1.0 FLR	1.4-2.3	E = 2.6 G = 2.8 DDr = 1.1	H = 3.6 K = 3.9 D = 1.8	3	4	5.5	18.8	0.4
1	A	CuSn4	PRET INNED vorverzinkt min. 0.8 µm	>1.0-2.5 FLR	2.1-3.1	E = 3.6 G = 3.8 DDr = 1.8	H = 4.7 K = 4.9 D = 2.6	3.3	4.3	5.8	18.8	0.4
1	A	CuSn4	PLAIN BLANK	0.5-1.0 FLK	2.0-2.7	E = 2.6 G = 2.8 DDr = 1.1	H = 3.9 K = 4.1 D = 2.4	3	4	5.5	18.8	0.4
1	M	CuNi12Zn24	PRET INNED vorverzinkt min. 0.8 µm	0.5-1.0 FLK	2.0-2.7	E = 2.6 G = 2.8 DDr = 1.1	H = 3.9 K = 4.1 D = 2.4	3	4	5.5	18.8	0.4
1	M	CuSn4	PRET INNED vorverzinkt min. 0.8 µm									
1	M	CuSn4	PRET INNED vorverzinkt min. 0.8 µm									
1	M	CuFe2	PRET INNED vorverzinkt min. 0.8 µm									
1	A	CuFe2	PRET INNED vorverzinkt min. 1 µm	0.5-1.0 FLR	1.4-2.3	E = 2.6 G = 2.8 DDr = 1.1	H = 3.6 K = 3.9 D = 1.8	3.0	4.0	5.5	18.8	0.4
1	A	CuSn4	PRET INNED vorverzinkt min. 1 µm	>1.0-2.5 FLR	2.1-3.1	E = 3.6 G = 3.8 DDr = 1.8	H = 4.7 K = 4.9 D = 2.6	3.3	4.3	5.8	18.8	0.4
1	N	CuSn4	PRET INNED vorverzinkt min. 1 µm	>1.0-2.5 FLK	2.7-4.1	E = 3.6 G = 3.8 DDr = 1.8	H = 5.5 K = 5.8 D = 3.6	3.3	4.3	5.8	18.8	0.4
1	R	CuSn4	PRET INNED vorverzinkt min. 1 µm	>1.0-2.5 FLR	2.1-3.1	E = 3.6 G = 3.8 DDr = 1.8	H = 4.7 K = 4.9 D = 2.6	3.3	4.3	5.8	18.8	0.4
1	R	CuFe2										
1	P	CuSn4										
1	P	CuFe2										
1	A	CuSn4	PRET INNED vorverzinkt min. 1 µm	0.5-1.0 FLR	1.4-2.3	E = 2.6 G = 2.8 DDr = 1.1	H = 3.6 K = 3.9 D = 1.8	3	4	5.5	18.8	0.4
1	N	CuSn4										
1	N	CuFe2										
1	M	CuSn4										
1	M	CuFe2	PRET INNED vorverzinkt min. 1 µm	0.2-0.5 FLR	1.0-1.6	E = 2.1 G = 2.1 DDr = 0.8	H = 2.7 K = 2.8 D = 1.4	2.5	3.5	5.6	18.8	0.4
1	C	CuSn4										
1	C	CuFe2										
1	B	CuSn4										
2	B	CuFe2	PRET INNED vorverzinkt min. 1 µm	0.08-0.2 Sonderleitung	1.5-1.8	E = 1.7 G = 1.7 DDr = 0.6	H = 3.1 K = 3.2 D = 1.6	2.5	3.7	5.9	18.8	0.4
2	B	CuSn4										
2	B	CuFe2										
2	B	CuFe2										
3	A	CuSn4	PRET INNED vorverzinkt min. 0.8 µm	0.2-0.5 FLK	1.2-2.3	E = 2.1 G = 2.1 DDr = 0.8	H = 3.5 K = 3.6 D = 2.0	2.5	3.5	5	18.8	0.4
3	C	CuSn4	PRET INNED vorverzinkt min. 0.8 µm	0.2-0.5 FLK	1.2-2.3	E = 2.1 G = 2.1 DDr = 0.8	H = 3.5 K = 3.6 D = 2.0	2.5	3.5	5	18.8	0.4
3	C	CuFe2										
3	C	CuFe2										
3	C	CuFe2										
4	A	CuSn4	PLAIN BLANK	0.2-0.5 FLR	1.15-1.6	E = 2.4 G = 2.3 DDr = 1	H = 2.9 K = 2.9 D = 1.4	2.5	3.5	5.6	18.8	0.2
5	E	CuSn4	PRET INNED vorverzinkt min. 1 µm	>1.0-2.5 FLK	2.7-3.0	E = 3.6 G = 3.8 DDr = 1.8	H = 5.4 K = 4.6 D = 3.2	3.5	5.9	7.5	18.8	0.4
5	E	CuFe2										
5	D	CuSn4										
5	D	CuFe2										
5	E	CuSn4	PRET INNED vorverzinkt min. 1 µm	>1.0-2.5 FLR	2.7-3.0	E = 3.6 G = 3.8 DDr = 1.8	H = 5.4 K = 4.6 D = 3.2	3.5	5.9	7.5	21	0.4
5	E	CuFe2										
5	E	CuSn4										
5	E	CuFe2										
5	E	CuSn4	PRET INNED vorverzinkt min. 1 µm	0.5-1.0 FLR	1.4-2.1	E = 2.6 G = 2.8 DDr = 1.1	H = 5.4 K = 4.6 D = 3.2	3	5.4	7	21	0.6
5	E	CuFe2										
5	G	CuSn4										
5	G	CuFe2										
5	F	CuSn4	PRET INNED vorverzinkt min. 1 µm	0.5-1.0 FLR	1.4-2.1	E = 2.6 G = 2.8 DDr = 1.1	H = 5.4 K = 4.6 D = 3.2	3	5.4	7	18.8	0.6
5	F	CuFe2										
5	F	CuSn4										
5	F	CuFe2										
6	E	CuSn4	PRET INNED vorverzinkt min. 1 µm	0.2-0.5 FLR	1.15-1.6	E = 2.1 G = 2.1 DDr = 0.8	H = 5.4 K = 4.6 D = 3.2	2.5	4.9	6.5	21	0.9
6	E	CuFe2										
6	D	CuSn4										
6	D	CuFe2										
6	D	CuSn4	PRET INNED vorverzinkt min. 1 µm	0.2-0.5 FLR	1.15-1.6	E = 2.1 G = 2.1 DDr = 0.8	H = 5.4 K = 4.6 D = 3.2	2.5	4.9	6.5	18.8	0.9
6	D	CuFe2										
6	D	CuSn4										
6	D	CuFe2										

SEE APPLICATION - SPECIFICATION  
 siehe Verarbeitungspezifikation  
 114-18050

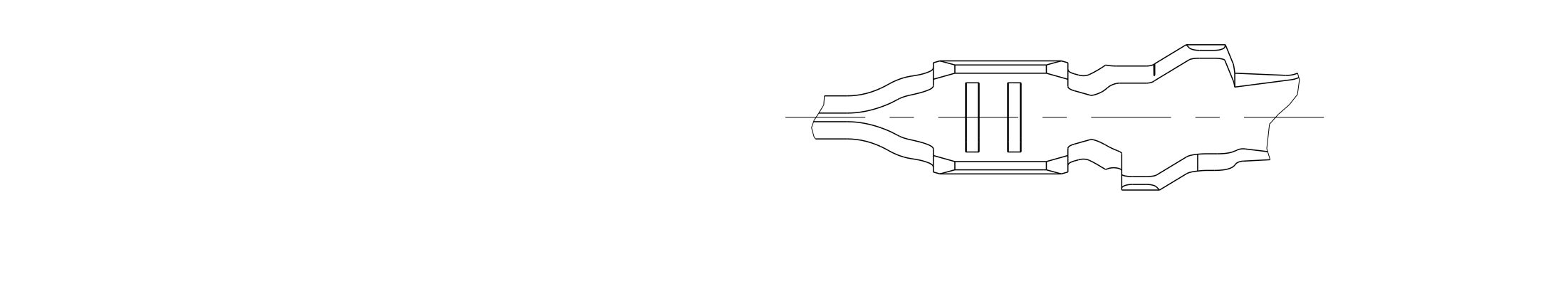
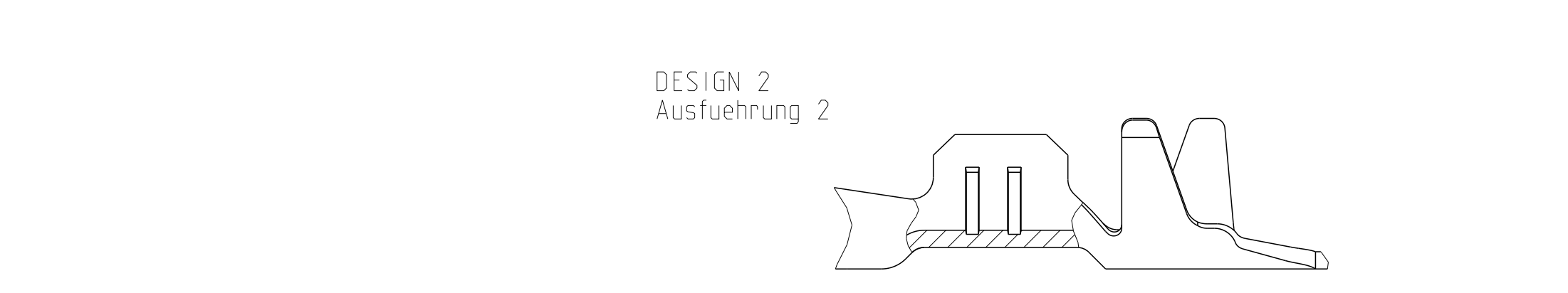
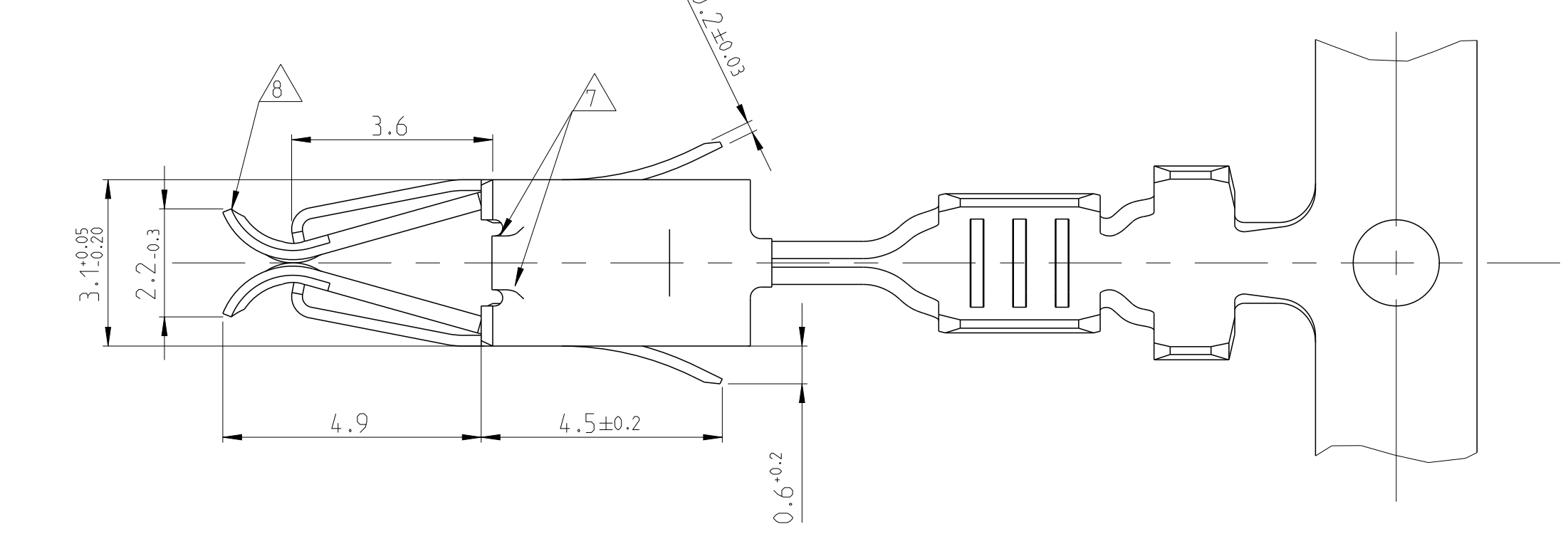
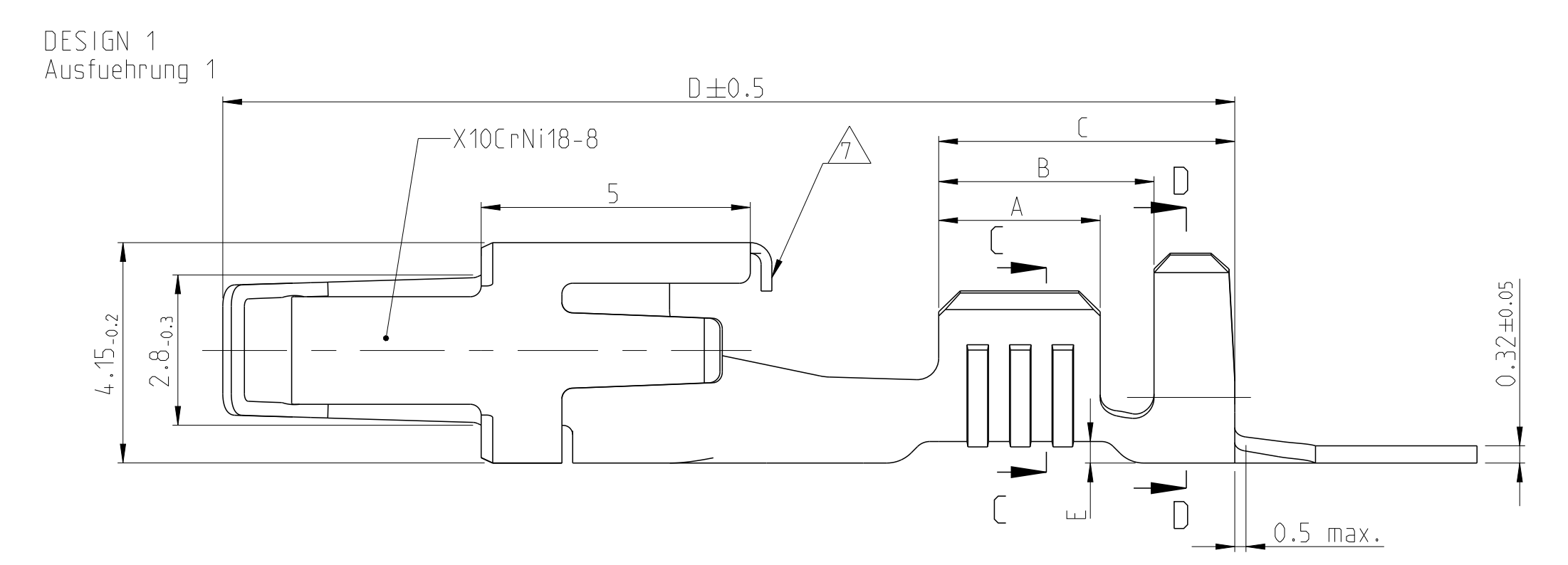

ORDER No. Bestell-Nr.	INSULATION Ø Isolations Ø	COLOUR Farbe
828904-1	1.2-2.1	blue blau
828905-1	2.2-3.0	white weiss

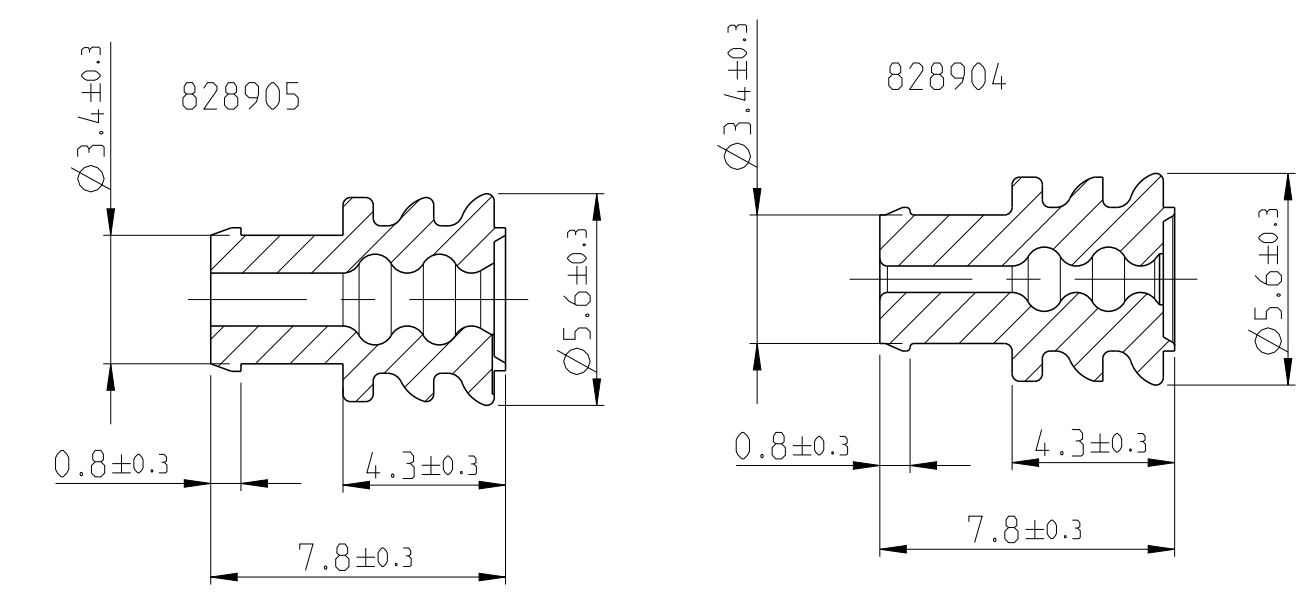

REVISIONS			
NO.	DATE	DESCRIPTION	BY
A13	19NOV13	Part status changed	Ho. Eder
A14	25SEP2014	New Creo drawing created	Ho. Eder
A15	26MAY2014	Material of PN 928810-1 corrected	Gilch Eder
A16	29NOV2014	Add PN's in the Table	Ho. Eder



- NOTES  
 Bemerkungen
- CONTACT BODY PRE-SILVER PLATED MIN. 0.8 µm  
 Kontaktkoerper vorversilbert min. 0.8 µm
  - CONTACT ZONE SELECTIVE PRE-SILVER PLATED MIN. 3 µm  
 Kontaktzone selektiv vorversilbert min. 3 µm
  - CONTACT ZONE GOLD PLATED MIN. 0.8 µm OVER MIN. 1.3 µm NICKEL-LAYER  
 Kontaktzone vergoldet min. 0.8 µm ueber min. 1.3 µm Nickel-Zwischenschicht
  - CANTILEVER SPRING INSIDE AND OUTSIDE 0.4-1.2 µm GOLD PLATED  
 Ueberfeder innen und aussen 0.4-1.2 µm vergoldet
  - CONTACT BODY, CONTACT SPRING INSIDE AND CRIMP AREA MIN. 1 µm TIN PLATED OVER NICKEL-LAYER.  
 TOUCHING AREA TO CANTILEVER SPRING AND CONTACT SPRING OUTSIDE  
 SELECTIVE 0.8 µm GOLD OVER MIN. 1.3 µm NICKEL-LAYER  
 Kontaktkoerper, Kontaktfeder innen und Crimbereich min. 1.3 µm verzinkt ueber Nickel-Zwischenschicht, Anlageflaeche zur Ueberfeder und Kontaktfeder aussen selektiv 0.8 µm vergoldet ueber min. 1 µm Nickel-Zwischenschicht
  - CONTACT ZONE AND TOUCHING AREA TO CANTILEVER SPRING MIN. 0.8 µm SELECTIVE GOLD PLATED OVER 1.3 µm NICKEL PLATED. CRIMP AREA MIN. 1 µm TIN PLATED OVER NICKEL-LAYER  
 Kontaktzone und Anlageflaeche zur Ueberfeder min. 0.8 µm vergoldet ueber min. 1.3 µm Nickel-Zwischenschicht Crimbereich min. 1 µm verzinkt ueber Nickel-Zwischenschicht
  - CONTACT BODY AND CRIMP AREA MIN. 1 µm TIN PLATED OVER NICKEL-LAYER.  
 TOUCHING AREA TO CANTILEVER SPRING SELECTIVE 0.8 µm GOLD OVER MIN. 1.3 µm NICKEL-LAYER  
 Kontaktkoerper und Crimbereich min. 1 µm verzinkt ueber Nickel-Zwischenschicht, Anlageflaeche zur Ueberfeder selektiv 0.8 µm vergoldet ueber min. 1.3 µm Nickel-Zwischenschicht
  - CONTACT OFF OPTIONAL  
 Abschnitt/Freisschnitt optional
  - SAWAG ONLY FOR PN 929937, 929939, 929941  
 Swage nur fuer PN 929937, 929939, 929941
  - VARIANTS WITH GAP-SIZE 0.3mm (±0.1)  
 Varianten mit Gap-Size 0.3mm (±0.1)
  - CONTACTS DIPPED IN OR SPRAYED WITH LUBRICANT BARRIERTA  
 Kontakte getaucht oder besprueht mit Lubricant Barrierta
  - ACCORDING INSULATION DIA IS TO CHOOSE THE SINGLE WIRE SEAL  
 Entsprechend dem Isolationsdurchmesser ist die Einzel-Dichtung auszuwaehlen
  - VARIANTS WITH GAP-SIZE 0.65mm (±0.1)  
 Varianten mit Gap-Size 0.65mm (±0.1)
  - VARIANTS WITH GAP-SIZE 0.15mm (±0.05)  
 Varianten mit Gap-Size 0.15mm (±0.05)

