

PRODUCT NO.

10125837-001\*\*GLF

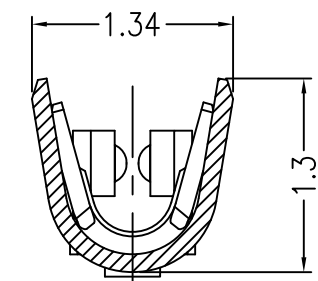
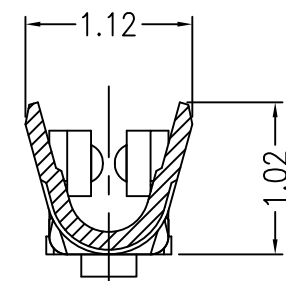
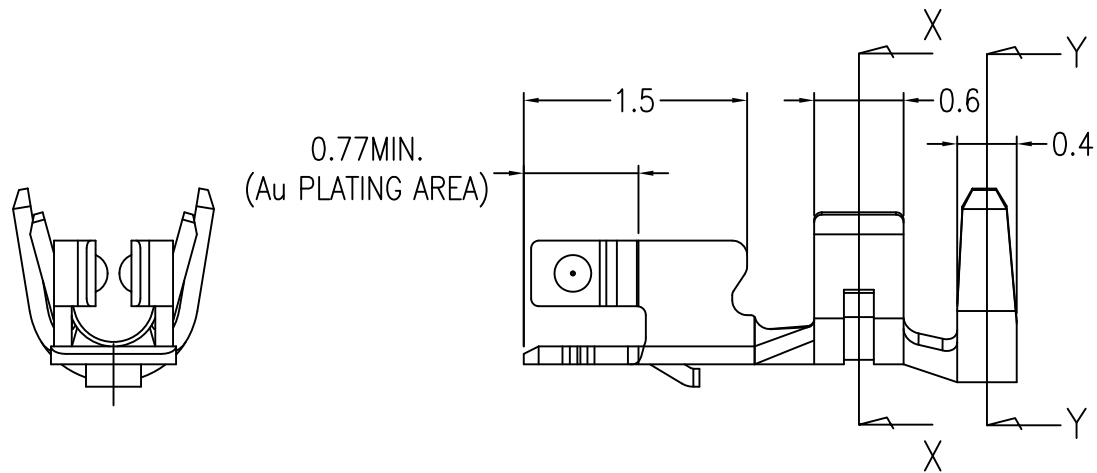
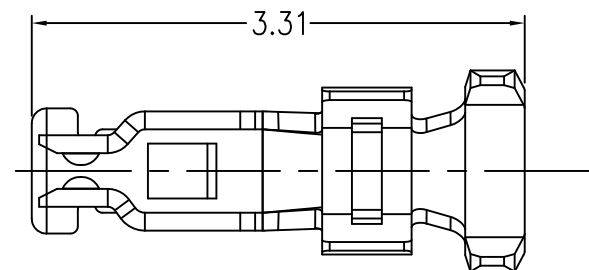
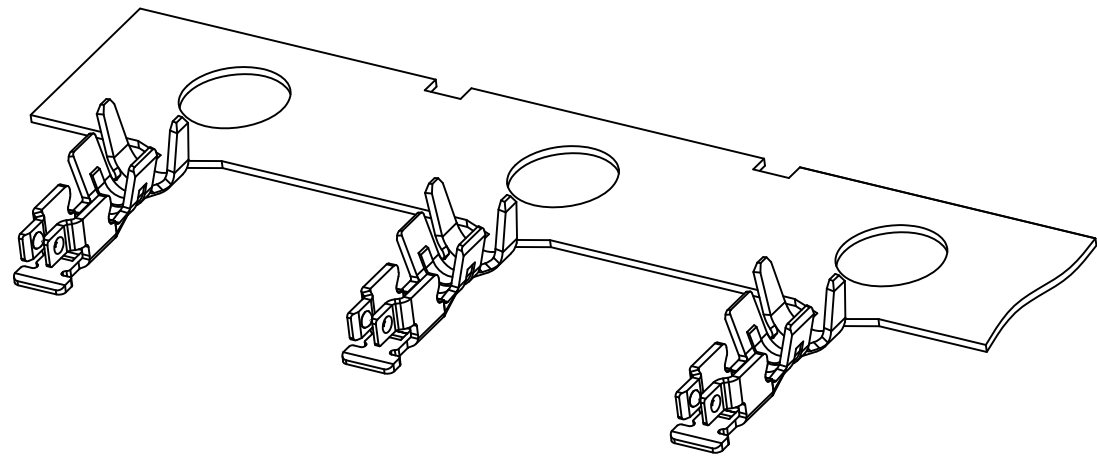

CROSS SECTION X-X  
(CONDUCTOR BARREL)

CROSS SECTION Y-Y  
(INSULATION BARREL)

NOTE

1. APPLICABLE HOUSING ; 10125836-\*\*\*\*\*
2. MATERIAL ; COPPER ALLOY
3. PLATING ; Au PLATING  
Ni UNDER PLATING
4. SPECIFICATIONS  
PRODUCT SPEC: GS-12-1189  
PACKAGING SPEC: GS-14-2373  
APPLICATION SPEC: GS-20-0393
5. Applicable crimp tool:  
a. Japan Automatic Machine ; EFS868900-UP  
b. Japan Chain Terminal ; OR-02-131Y
6. This product meets European Union Directives and other country regulations as described in GS-47-0004.
7. "A" symbol will be next to any dimension, view, or note which has been modified with the current drawing revision."

Hitachi Metals,LTD : UL STYLE 10368 (HALOGEN FREE AS RoHS COMPLIED WIRES)

	SPECIFICATIONS				
	AWG#	STRANDING (No./mm)	SECT. AREA (mm <sup>2</sup> )	INSULATION O.D (mm)	RATING
UL 10368 STRANDED WIRE	28	7/0.127	0.089	0.88	105 deg. C , 300V
	30	7/0.102	0.057	0.8	105 deg. C , 300V

SUZHOU RENDE SCIENCE AND TECHNOLOGY : UL STYLE 10368 (HALOGEN FREE AS RoHS COMPLIED WIRES)

	SPECIFICATIONS				
	AWG#	STRANDING (No./mm)	SECT. AREA (mm <sup>2</sup> )	INSULATION O.D (mm)	RATING
UL 10368 STRANDED WIRE	30	7/0.1	0.055	0.75	105 deg. C , 300V

25,000 x 5REEL = 125,000		25,000		CHAIN	10125837-001GLF
25,000 x 1REEL = 25,000					10125837-001SPGLF
PRODUCT QTY / BOX		PRODUCT QTY / REEL		FORM	PRODUCT NO.
mat'l. code SEE_TABLE		surface ISO 1302 <input checked="" type="checkbox"/> ISO 406 ISO 1101	tolerance ISO 406 ISO 1101	projection 	product family
ltr	ecn no	dr	date	tolerances unless otherwise specified	
A		Y.K	2013-10-25	angles	0.X/±0.3
B	ELX-J-17474	Y.K	2014-04-16	linear	0.XX/±0.3
C	ELX-J-25457	Y.K	2016-11-25	0°±3'	0.XXX/±0.3
		dr	Y.KAMEDA	2014-04-16	
		enr	Y.KAMEDA	2014-04-16	
		chr	H.SUZUKI	2014-04-16	
		appd	N.SASAME	2014-04-16	
sheet index	revision sheet	C	C	C	C
		1	2	3	4
		dwg no		sheet 1 of 4	size
		10125837		A3	5
		type		CUSTOMER Drawing	

PRODUCT NO.

10125837-001\*\*GLF

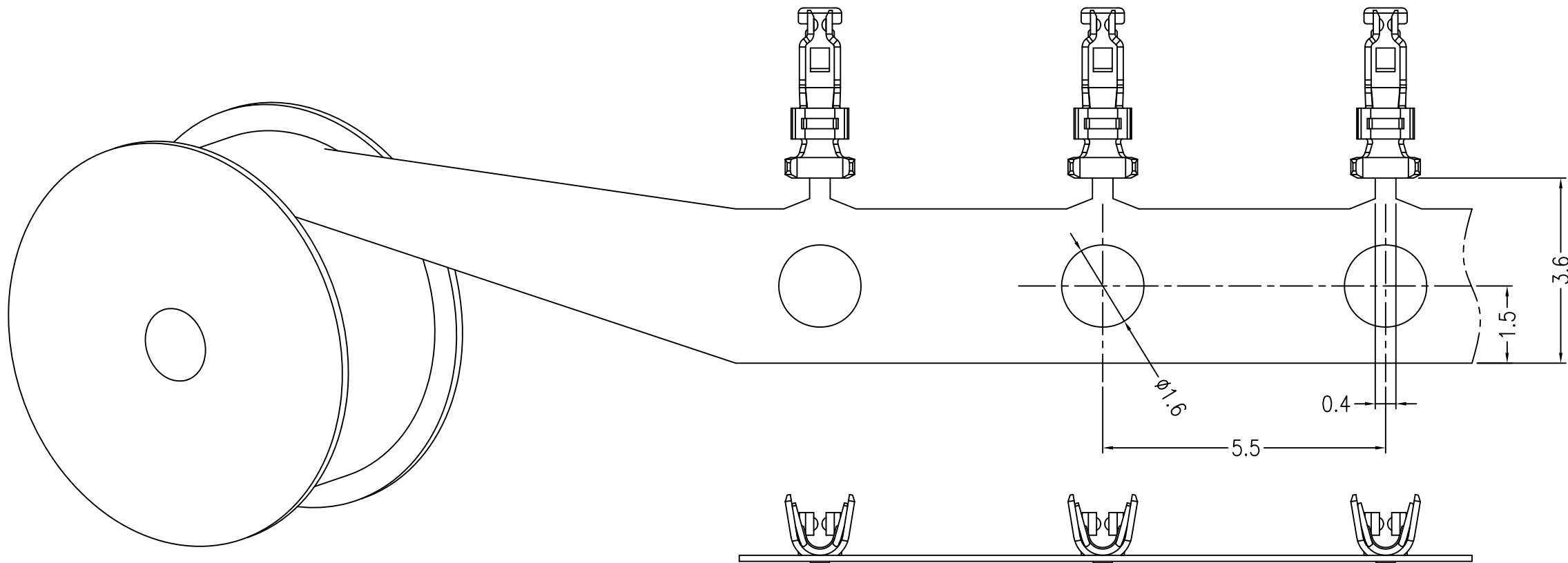

Amphenol  
FCi

© 2016 AFci

CHAIN 10125837-001\*\*GLF

FORM PRODUCT NO.

mat'l. code		surface		tolerance		projection		product family	
SEE_TABLE		ISO 1302 ✓		ISO 406 ISO 1101				title	
		tolerances unless otherwise specified		0.X/±0.3		MM		CRIMP TERMINAL	
ltr	ecn no	dr	date	angles	linear	0.XX/±0.3		FOR 1.2mm PITCH WTB CONNECTOR	
A		Y.K	2013-10-25			0.XXX/±0.3		scale 10:1	
B	ELX-J-17474	Y.K	2014-04-16						
C	ELX-J-25457	Y.K	2016-11-25	0°±3'					
		dr	Y.KAMEDA	2014-04-16			dwg no		sheet 2 of 4
		enr	Y.KAMEDA	2014-04-16			10125837		size 5
		chr	H.SUZUKI	2014-04-16			type		A3
		appd	N.SASAME	2014-04-16			CUSTOMER Drawing		
sheet index	revision sheet								

PRODUCT NO.

10125837-001\*\*GLF

SPECIFICATION

ITEM		REQUIREMENT	NOTE
INSULATION POSITION	C	0.1~0.25mm (REF.)	
EXTRUDED WIRE LENGTH	D	0.1~0.5mm (REF.)	
BELL MOUTH	E	0.1~0.25mm (REF.)	
BEND UP	F	3° MAX.	
BEND DOWN	G	2° MAX.	
TWISTING	H	±3° MAX.	
ROLLING	I	±3° MAX.	
CUT OFF TAB LENGTH	J	0.1mm MAX.	
WIRE STRIP LENGTH	K	1~1.3mm (REF.)	BEFORE STRIP LENGTH
HEIGHT OF CUT-OUT TEETH	L	0.05mm MAX.	
WIDE (CONDUCTOR BARREL)	M	0.95mm MAX.	
WIDE (INSULATION BARREL)	N	0.95mm MAX.	
CONTACT GAP	P	0.08mm (REF.)	

AFTER CRIMPING, THE CRIMPED AREA SHOULD BE AS BELOW TABLE.

	CRIMP CONDITION			
	WIRE SIZE (AWG)	CRIMP HEIGHT		CRIMP STRENGTH (N)
		CONDUCTOR SIDE (mm)	INSULATION SIDE (mm) (REFERENCE)	
UL 10368 STRANDED WIRE (HITACHI METALS)	#28	0.44~0.48	1.0~1.05	10
	#30	0.43~0.48	0.95~1.0	5
UL 10368 STRANDED WIRE (SUZHOU RENDE SCIENCE AND TECHNOLOGY)	#30	0.42~0.47	0.91~0.95	5

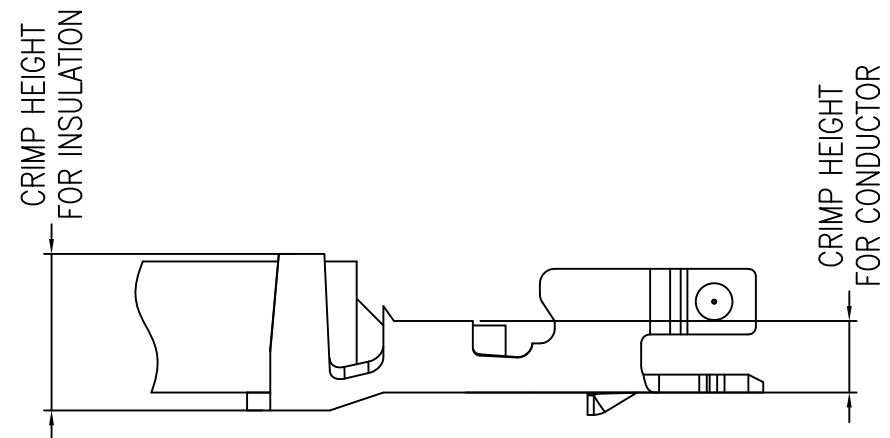
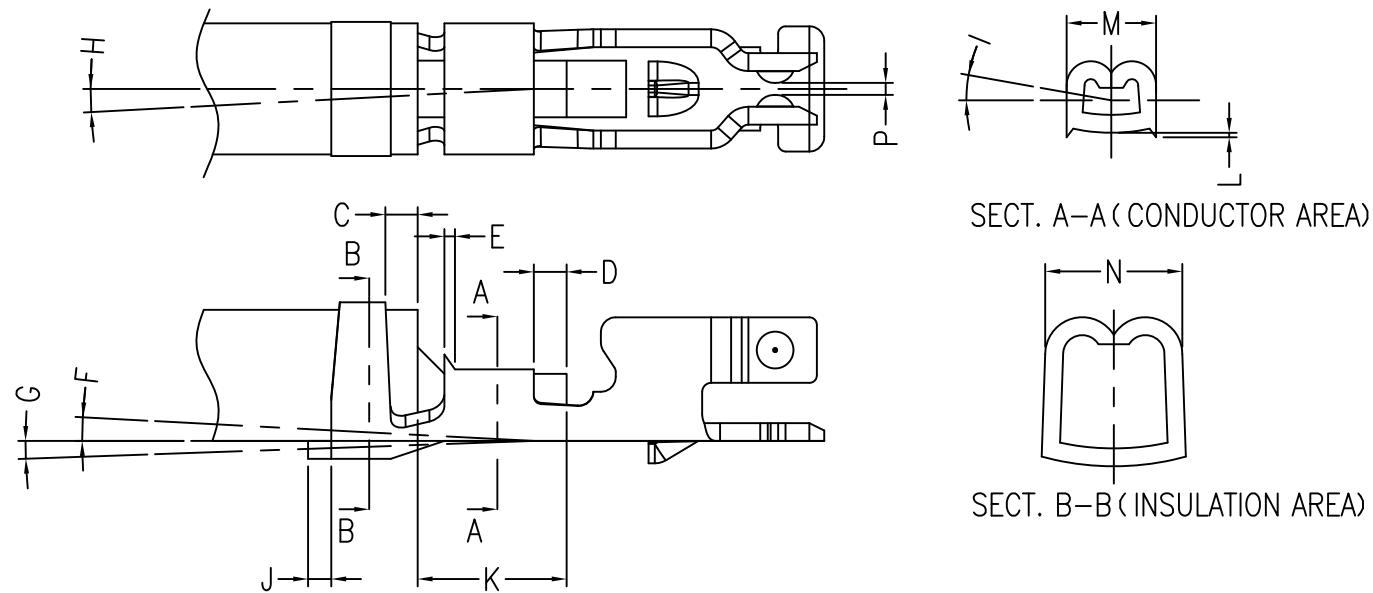

CHAIN	10125837-001**GLF
FORM	PRODUCT NO.

mat'l. code		surface		tolerance		projection		product family	
SEE_TABLE		ISO 1302 ✓		ISO 406 ISO 1101					
		tolerances unless otherwise specified		0.X/±0.3		MM		title	
ltr		ecn no		dr		date		CRIMP TERMINAL	
A		Y.K		2013-10-25				FOR 1.2mm PITCH WTB CONNECTOR	
B		ELX-J-17474		Y.K		2014-04-16			
C		ELX-J-25457		Y.K		2016-11-25			
		dr		Y.KAMEDA		2014-04-16		dwg no	
		enr		Y.KAMEDA		2014-04-16		sheet 3 of 4	
		chr		H.SUZUKI		2014-04-16		size	
		appd		N.SASAME		2014-04-16		A3	
sheet index		revision sheet						type	
								CUSTOMER Drawing	

Amphenol FCI

© 2016 AFCl

PRODUCT NO.

10125837-001\*\*GLF

\*TERMINAL INSERTION DIRECTION

AFTER TERMINAL INSERTION

DIRECTION OF TERMINAL RANGE

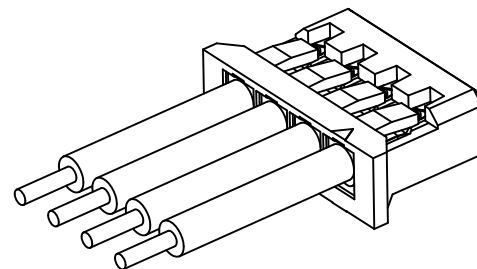
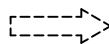
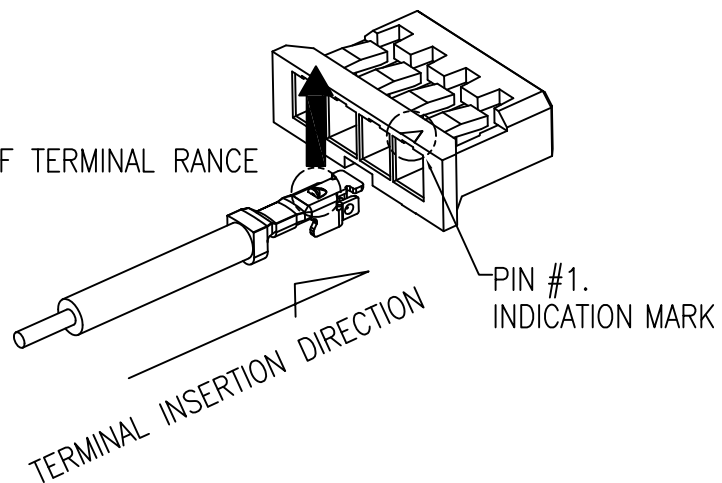

\*NOTE THE DIRECTION OF THE TERMINAL RANGE WHEN THE TERMINAL ENTER THE HOUSING. (REFER TO THE UPPER FIGURE)

BEFORE MATING CONDITION

AFTER MATING CONDITION

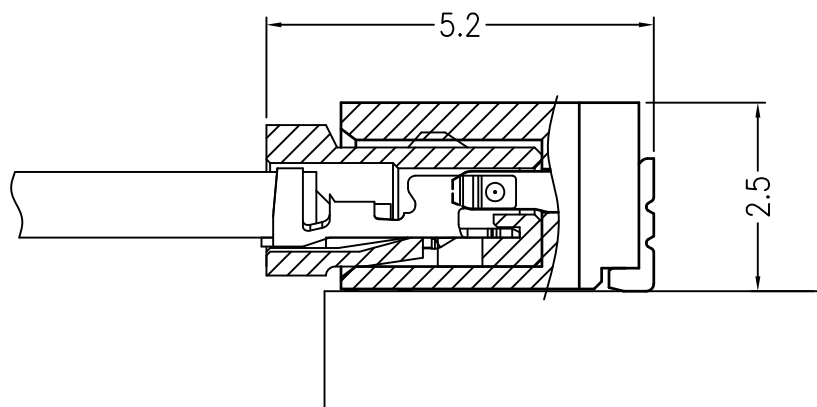
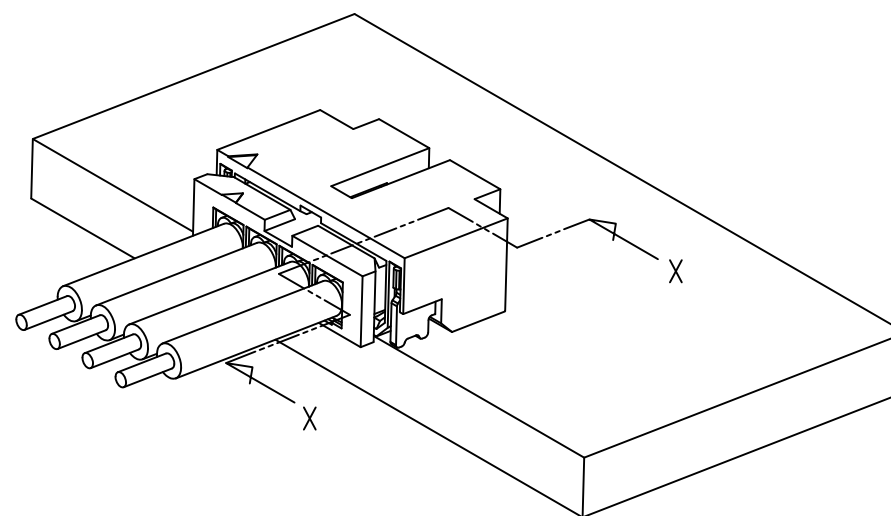
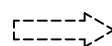
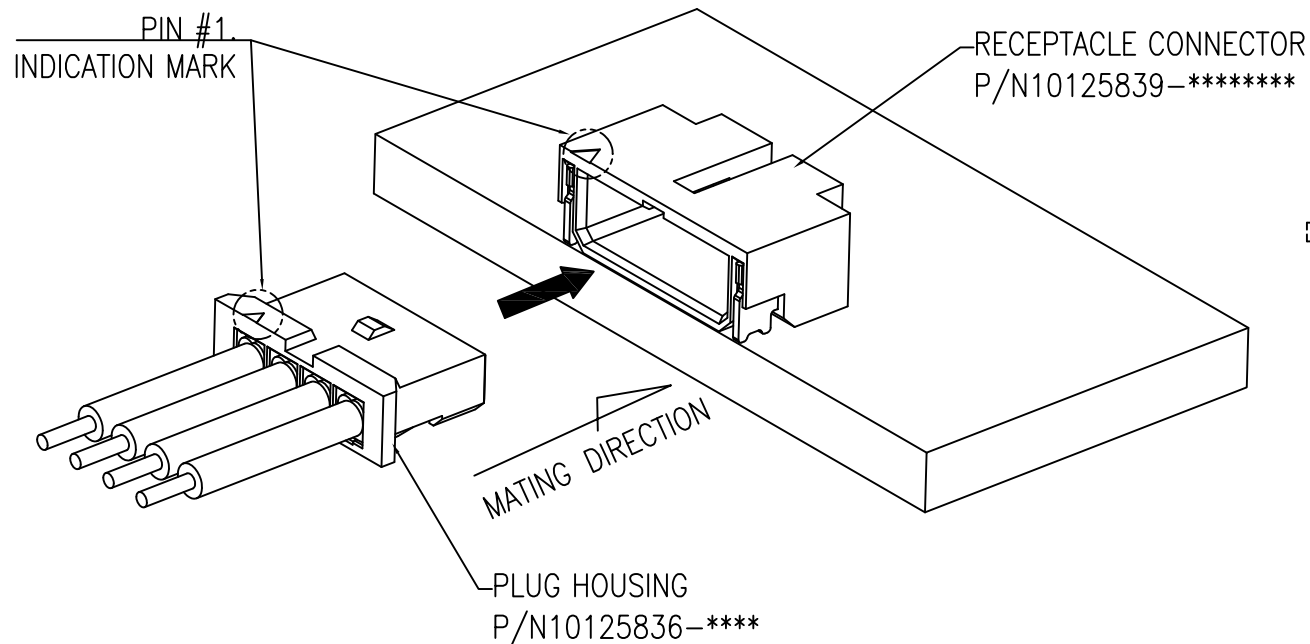

SECTION X-X (SCALE: 10:1)

mat'l. code		surface		tolerance		projection		product family	
SEE_TABLE		ISO 1302 ✓		ISO 406 ISO 1101					
ltr	ecn no	dr	date	tolerances unless otherwise specified		MM		title	
A		Y.K	2013-10-25	angles	linear	0.X/±0.3		CRIMP TERMINAL FOR 1.2mm PITCH WTB CONNECTOR	
B	ELX-J-17474	Y.K	2014-04-16			0.XX/±0.3			
C	ELX-J-25457	Y.K	2016-11-25			0.XXX/±0.3			
				dr	Y.KAMEDA	2014-04-16	scale 5:1		dwg no
				enr	Y.KAMEDA	2014-04-16	Amphenol FCI		sheet 4 of 4
				chr	H.SUZUKI	2014-04-16			size
				appd	N.SASAME	2014-04-16			A3
sheet index		revision sheet						type	
								CUSTOMER Drawing	

Amphenol FCI

© 2016 AFCl